



样本 2016-03 | Catalog March 2016

低压一般用途电机

Low voltage General performance motors

用电力与效率
创造美好世界™



我们提供电机、发电机、机械传动产品、各项相应服务及专门技术，帮助客户在产品的整个使用周期及更长的期限内，实现节能及工艺改进。

We provide motors, generators and mechanical power transmission products, services and expertise to save energy and improve customers' processes over the total life cycle of our products, and beyond.

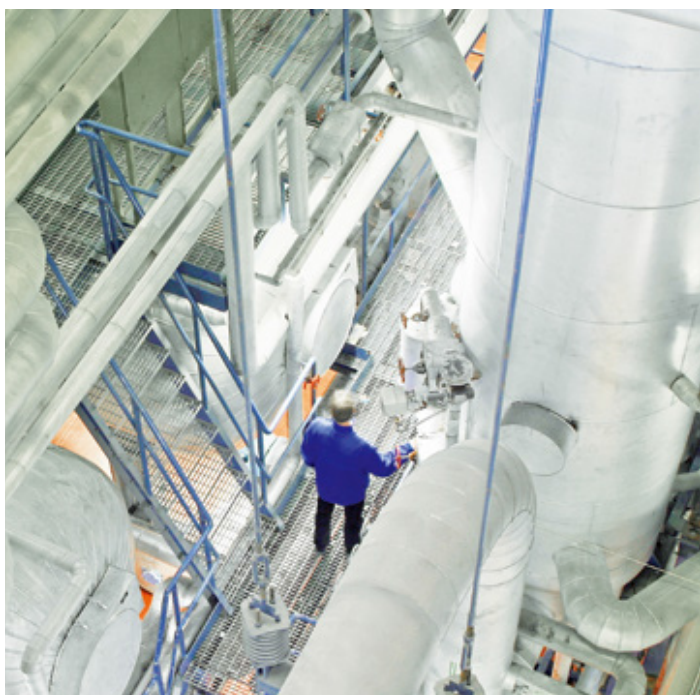

目录

Content

产品概述	4	General information	4
订购信息	7	Ordering information	7
铭牌	8	Rating plates	8
电气特性	9	Electrical design	9
机械设计	12	Mechanical design	12
变频器驱动	19	Variable speed drives	19
技术数据 IE2	24	Technical data IE2	24
技术数据 IE3	30	Technical data IE3	30
外形图及外形尺寸	36	Dimension drawings	36
变量代码	41	Variant codes	41
一般用途电机简介	45	General performance motors in brief	45

ABB 低压电机拥有了 ABB 的一流品质和雄厚支持，这些电机的性能得到大量客户和 OEM（原始设备制造商）的认可。电机达到 IE2, IE3 效率。

ABB Low voltage motors are with ABB quality and support. These motors have the features appreciated by volume customers and serial OEMs. Motors achieve IE2 and IE3 efficiency.

产品概述

General information

标准

ABB 电机采用全封闭三相鼠笼型设计，其工艺符合 IEC 和 EN 国际标准。同时，可按要求提供符合其他国家规范的电机。

所有生产厂家均通过 ISO 9001 国际质量认证及 ISO 14000 环境标准，并符合所有适用的欧盟指令。



产品简介

ABB M2BAX 系列产品是用于一般用途的低压高效三相异步电动机。该系列电机通过 ABB 全球研发平台设计，面对全球及中国市场。设计遵循 IEC 国际标准以及中国 GB 标准，效率达到 IE2，IE3 能效等级。符合中国 2 级，3 级能效标准（GB18613-2012）。

M2BAX 系列电机主要是针对大批量购买电机的 OEM 客户设计，其应用包括风机、水泵、减速机等，可适用于水处理、暖通空调、食品饮料、纺织、电力、机床、造纸、冶金等行业。M2BAX 的优异品质及服务为客户提供了增值的空间，其标准电机的库存设计和更短的供货周期确保了订单的快速交付，更高的产品灵活性可满足各类客户需求。

Standards

ABB motors are of the totally enclosed, three phase squirrel cage type, built to comply with international IEC and EN standards. Motors conforming to other national and international specifications are also available on request.

All production units are certified to ISO 9001 international quality standard as well ISO 14000 environmental standard and conform to all applicable EU Directives.

IEC/EN

电气 Electrical	机械 Mechanical
IEC/EN 60034-1	IEC 60072
IEC/EN 60034-2-1	IEC/EN 60034-5
IEC/EN 60034-30	IEC/EN 60034-6
IEC/EN 60034-8	IEC/EN 60034-7
IEC/EN 60034-12	IEC/EN 60034-8
	IEC 60034-14

Brief

M2BAX - Low voltage general performance motors are ABB high efficiency products. This series of motors are designed for both the Chinese market and export. Product development is on ABB strong R&D platform. The design is in line with international IEC standards and China local GB standards. The efficiency level reaches IE3 and IE2, equivalent to Grade 2 and Grade 3 (GB18613-2012).

M2BAX is specially designed for OEM customers, mainly integrated with fans, pumps and gear boxes. Main applications include Water & Waste water treatment, HVAC, Food & Beverage, Textile, Power, Pulp & Paper, Metal and others industries. The high quality of M2BAX and the excellent service of ABB continuously make value for the customers. Standard motors are on stock, which can shorten lead time and ensure a fast delivery. Higher product flexibilities lead to meet the ever-changing need from our customers.

产品概述 - 安装结构形式

General information - Mounting arrangements

底脚安装型电机

Foot-mounted motor

代码 I / 代码 II

Code I / code II

						<p>产品代码位置 12 Product code pos. 12</p> <p>A = 底脚安装型, 接线盒在顶部 foot-mounted, term.box top</p>
IM B3	IM V5	IM V6	IM B6	IM B7	IM B8	M000007
IM 1001	IM 1011	IM 1031	IM 1051	IM 1061	IM 1071	

凸缘安装型电机, 大凸缘

Flange-mounted motor, large flange

代码 I / 代码 II

Code I / code II

						<p>产品代码位置 12 Product code pos. 12</p> <p>B = 凸缘安装型, 大凸缘 flange mounted, large flange</p>
IM B5	IM V1	IM V3	*)	*)	*)	M000008
IM 3001	IM 3011	IM 3031	IM 3051	IM 3061	IM 3071	

凸缘安装型电机, 小凸缘

Flange-mounted motor, small flange

代码 I / 代码 II

Code I / code II

						<p>变量代码 variant code</p> <p>047 = B5 派生出 B14 B14 from B5</p>
IM B14	IM V18	IM V19	*)	*)	*)	M000009
IM 3601	IM 3611	IM 3631	IM 3651	IM 3661	IM 3671	

底脚和凸缘安装型电机, 大凸缘

Foot- and flange-mounted motor with feet, large flange

代码 I / 代码 II

Code I / code II

						<p>变量代码 variant code</p> <p>009 = B3 派生出 B35 B35 from B3</p>
IM B35	IM V15	IM V36	*)	*)	*)	M000010
IM 2001	IM 2011	IM 2031	IM 2051	IM 2061	IM 2071	

底脚和凸缘安装型电机, 小凸缘

Foot- and flange-mounted motor with feet, small flange

代码 I / 代码 II

Code I / code II

						<p>变量代码 variant code</p> <p>008 = B3 派生出 B34 B34 from B3</p>
IM B34	IM V17	IM 2131	IM 2151	IM 2161	IM 2171	M000011
IM 2101	IM 2111	IM 2131	IM 2151	IM 2161	IM 2171	

产品概述 - 防护等级：IP 代码 / IK 代码

General information - Degrees of protection: IP code/IK code

按旋转电机外壳提供的防护等级分类符合

- 对于 IP 代码，适用 IEC 60034-5 或 EN 60529
- 对于 IK 代码，适用 EN 50102

IP 防护

防止人员接触（或接近）带电部件，以及机壳内的运转部件。同时避免外界固体异物侵入机器内，保护机器，避免进水防止受到有害影响。

IK 代码

机壳保护电机不受外部机械冲击不利影响的程度分级。

Classification of degrees of protection provided by enclosures of rotating machines refers to:

- Standard IEC 60034-5 or EN 60529 for IP code
- Standard EN 50102 for IK code

IP protection

Protection of persons against getting in contact with (or approaching) live parts and against contact with moving parts inside the enclosure. Also protection of the machine against ingress of solid foreign objects. Protection of machines against the harmful effects due to the ingress of water.

IK code

Classification of degrees of protection provided by enclosure for motors against external mechanical impacts.

IP 代码说明

Explanation of the IP code

特征字母 Ingress protection	对人和机壳内电机部件的保护程度 Degree of protection to persons and to parts of the motors inside the enclosure	机壳防止机器进水，遭受有害影响的防水程度 Degree of protection provided by the enclosure with respect to harmful effects due to ingress of water
IP	5	5
	1	2

位置1

Position 1

- 2: 防止大于 12mm 的固体进入机壳
Motors protected against solid objects greater than 12 mm
- 4: 防止大于 1mm 的固体进入机壳
Motors protected against solid objects greater than 1 mm
- 5: 防尘保护电机
Dust-protected motors
- 6: 隔尘电机
Dust-tight motors

位置2

Position 2

- 3: 使电机被溅水后不受损害
Motors protected against spraying water
- 4: 使电机被淋水后不受损害
Motors protected against splashing water
- 5: 使电机被喷水后不受损害
Motors protected against water jets
- 6: 使电机遭大浪后不受损害
Motors protected against heavy seas

IK 代码说明

Explanation of the IK code

国际机械保护 International mechanical protection	特征组 Characteristic group
IK	08
	1

位置1

Position 1

IK代码和冲击能量之间的关系:

Relation between IK code and impact energy:

IK代码: 冲击能量焦耳

IK code: Impact energy/Joule

0:	不按照EN 50102提供保护 Not protected according to EN 50102
01:	0.15
02:	0.2
03:	0.35
04:	0.5
05:	0.7
06:	1
07:	2
08:	5 (ABB 标准) 5 (ABB Standard)
09:	10
10:	20

订购信息

Ordering information

订购时，请按照示例在订单中说明以下最小数据。电机产品代码根据以下示例编写。

示例	
电机型号	M2BAX 112 MA
极数	4
安装方式 (IM 代码)	IM B3 (IM1001)
额定输出	4 kW
产品代码	3GBA 112 310-ADCCN
附加代码 (如需)	

When placing an order, please state the following minimum data in the order, as in the example. The product code of the motor is composed in accordance with the following example.

Example	
Motor type	M2BAX 112 MA
Pole number	4
Mounting arrangement (IM-code)	IM B3 (IM1001)
Rated output	4 kW
Product code	3GBA 112 310-ADCCN
Variant codes if needed	

产品代码说明

Explanation of the product code

电机型号 Motor type	电机尺寸 Motor size	产品代码 Product code	安装方式代码, 电压及频率代码, 产品族代码 Mounting arrangement, voltage and frequency code, generation codes	变量代码 Variant codes
M2BAX	112MA	3GBA 112 310 - ADCCN	1 2 3 4 5 6 7 8 9 10 11 12 13 14	002, etc

位置 1-4 3GBA = 全封闭铸铁机座电机
位置 5-6 IEC 机座
07 = 71 11 = 112 20 = 200 31 = 315 08 = 80 13 = 132 22 = 225 35 = 355 09 = 90 16 = 160 25 = 250 10 = 100 18 = 180 28 = 280
位置 7 极对数
1=2 极 2=4 极 3=6 极
位置 8 -10 序列号
位置 11 -(破折号)
位置 12 安装方式
A = 底脚安装型电机 B = 凸缘安装型电机带通孔的大凸缘。
位置 13 电压和频率
D 380 V Δ, 400 V Δ, 660 VY 50 Hz S 220 V Δ, 380 VY, 400 VY 50 Hz
位置 14 产品族代码

Positions 1 to 4 3GBA = Totally enclosed motor with cast iron frame
Positions 5 to 6 IEC size
07 = 71 11 = 112 20 = 200 31 = 315 08 = 80 13 = 132 22 = 225 35 = 355 09 = 90 16 = 160 25 = 250 10 = 100 18 = 180 28 = 280
Positions 7 Speed (pole pairs)
1=2 poles 2=4 poles 3=6 poles
Positions 8 to 10 Serial number
Positions 11 -(dash)
Position 12 Mounting arrangement
A = Foot-mounted motor B = Flange-mounted motor. Large flange with clearance holes.
Position 13 Voltage and frequency
D 380 V Δ, 400 V Δ, 660 VY 50 Hz S 220 V Δ, 380 VY, 400 VY 50 Hz
Position 14 Generation code

铭牌

Rating plates

铭牌以表格形式提供六个电压的转速、电流和功率因数的数值。

The rating plates are in table form giving values for speed current and power factor for six voltages.

IE2
机座号 71-355
铭牌示例

IE2
Motor sizes 71 to 355
Rating Plate sample

ABB							
IE2 IEC 60034-1							
3 ~ Motor		M2BAX 80MA2			IMB3/IM1001		
No.							
V	Hz	kW	r/min	A	Ins.cl. $\cos \varphi$	F	IP 55 Duty
400 Y	50	0.75	2830	1.69	0.83		S1
230 Δ	50	0.75	2830	2.94	0.83		S1
380 Y	50	0.75	2797	1.71	0.86		S1
220 Δ	50	0.75	2797	2.96	0.86		S1
440 Y	60	0.75	3428	1.59	0.82		S1
460 Y	60	0.75	3445	1.58	0.79		S1
50Hz: IE2-77.4(100%)							
Prod. code 3GBA081310-ASCCN							
6204-2Z/C3		6203-2Z/C3		13 kg			

ABB							
IE2 IEC 60034-1							
3 ~ Motor		M2BAX 160MLA4			IMB3/IM1001		
No.							
V	Hz	kW	r/min	A	Ins.cl. $\cos \varphi$	F	IP 55 Duty
690 Y	50	11	1466	13.0	0.79		S1
400 Δ	50	11	1466	22.4	0.79		S1
660 Y	50	11	1461	13.2	0.82		S1
380 Δ	50	11	1461	22.7	0.82		S1
440 Δ	60	11	1770	19.1	0.83		S1
460 Δ	60	11	1773	18.7	0.81		S1
50Hz: IE2-89.8(100%)							
Prod. code 3GBA162410-ADCCN							
6209-2Z/C3		6209-2Z/C3		110 kg			

IE3
机座号 71-355
铭牌示例

IE3
Motor sizes 71 to 355
Rating plate sample

ABB							
CE IE3 IEC 60034-1							
3 ~ Motor		IE3 M2BAX 80MC2			IMB3/IM1001		
No.							
V	Hz	kW	r/min	A	Ins.cl. $\cos \varphi$	F	IP 55 Duty
400 Y	50	0.75	2890	1.66	0.81		S1
230 Δ	50	0.75	2890	2.88	0.81		S1
380 Y	50	0.75	2876	1.68	0.84		S1
220 Δ	50	0.75	2876	2.90	0.84		S1
440 Y	60	0.75	3496	1.52	0.84		S1
460 Y	60	0.75	3507	1.59	0.77		S1
50Hz: IE3-80.7(100%)							
Prod. code 3GBA081330-ASDCN							
6204-2Z/C3		6203-2Z/C3		15 kg			

ABB							
CE IE3 IEC 60034-1							
3 ~ Motor		IE3 M2BAX 160MLA4			IMB3/IM1001		
No.							
V	Hz	kW	r/min	A	Ins.cl. $\cos \varphi$	F	IP 55 Duty
690 Y	50	11	1477	12.3	0.82		S1
400 Δ	50	11	1477	21.2	0.82		S1
660 Y	50	11	1474	12.7	0.83		S1
380 Δ	50	11	1474	22.0	0.83		S1
440 Δ	60	11	1778	18.8	0.83		S1
460 Δ	60	11	1777	18.2	0.82		S1
50Hz: IE3-91.4(100%)							
Prod. code 3GBA162410-ADFCN							
6209-2Z/C3		6209-2Z/C3		139 kg			

说明:
铭牌图片仅供格式参考, 最终数据以实际铭牌为准。

Remark:
The format of the rating plate is for reference only. The final figure will be subject to the actual rating plate.

电气特性

Electrical design

额定输出

M2BAX 系列电机的额定功率是指电机运行在 S1- 连续工作制的情况下 (IEC 60034-1)，此时周围环境温度范围为 $-20^{\circ}\text{C} \sim 40^{\circ}\text{C}$ ，海拔高度不超过 1000m。

电压、频率

IEC 60034-1 定义了电压和频率的波动对温升的影响。标准将电压和频率的综合变化分为 A 和 B 两个区域。区域 A 是电压偏差 $\pm 5\%$ 和频率偏差 $\pm 2\%$ 的情况；区域 B 是电压偏差 $\pm 10\%$ 和频率偏差 $+3\%/-5\%$ 的情况。

电机均能在 A 和 B 两区域内提供额定转矩，但温升会高于在额定电压和频率情况下的值。电机只允许在区域 B 中短时间运行。

Rated Output

M2BAX motors rated outputs means that the motor runs under continuous duty S1 (IEC 60034-1) operation at ambient temperature from $-20^{\circ}\text{C} \sim 40^{\circ}\text{C}$ and at altitudes of up to 1000 m above sea level.

Voltage and Frequency

The impact on temperature rise caused by voltage and frequency fluctuation is defined in IEC 60034-1. The standard divides the combinations into two zones, zone A and B. Zone A is the combination of voltage deviation $\pm 5\%$ and frequency deviation $\pm 2\%$. Zone B is the combination of voltage deviation $\pm 10\%$ and frequency deviation $+3\%/-5\%$.

The motors are capable of supplying the rated torque in both zone A and B, but the temperature rise will be higher than at rated voltage and frequency. The motors are to be in operation only for a short period of time in zone B.

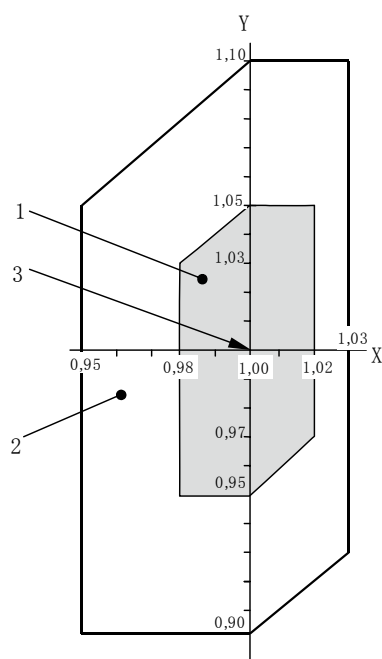

X 轴 频率标么值

Y 轴 电压标么值

1 区域 A

2 区域 B (区域 A 外)

3 额定点

X axis frequency p.u.

Y axis voltage p.u.

1 zone A

2 zone B (outside zone A)

3 rating point

电气特性

Electrical design

绝缘系统

ABB 采用 F 级绝缘材料，B 级温升，是当今业界最通用的要求。

F 级绝缘系统 B 级温升的采用，使 ABB 产品可获得 25°C 的安全裕度。这使电机在短时间内过载使用，或在较高环境温度和海拔，或在高电压和频率容差下使用成为可能。这一设计同样可用于延长绝缘寿命。例如，温度降低 10K，绝缘寿命延长。

B 级绝缘 (130°C)

- 额定环境温度 40°C
- 最大允许温升 80K
- 热点温升裕度 10K

F 级绝缘 (155°C)

- 额定环境温度 40°C
- 最大允许温升 105K
- 热点温升裕度 10K

H 级绝缘 (180°C)

- 额定环境温度 40°C
- 最大允许温升 125K
- 热点温升裕度 10K

Insulation

ABB uses class F insulation, which with temperature rise B, is the most common requirement among industry today. The use of class F insulation with class B temperature rise gives ABB products a 25°C safety margin. This can be used to increase the loading for limited periods, to operate at higher ambient temperatures or altitudes, or with greater voltage and frequency tolerances. It can also be used to extend insulation life. For instance, a 10 K temperature reduction will extend the insulation life.

Thermal class 130 (B)

- Nominal ambient temperature 40°C
- Max permissible temperature rise 80K
- Hot spot temperature margin 10K

Thermal class 155 (F)

- Nominal ambient temperature 40°C
- Max permissible temperature rise 105K
- Hot spot temperature margin 10K

Thermal class 180 (H)

- Nominal ambient temperature 40°C
- Max permissible temperature rise 125K
- Hot spot temperature margin 10K

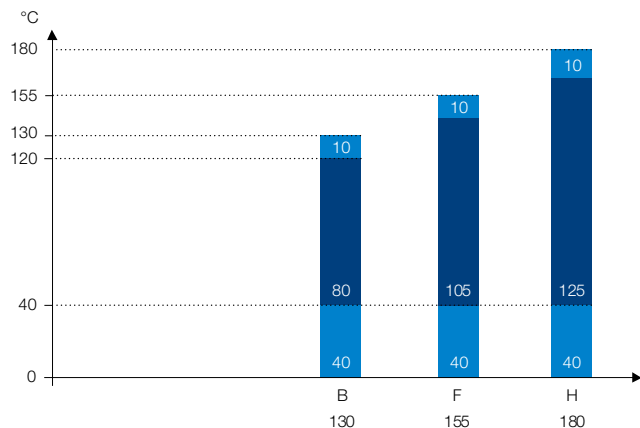

各绝缘等级的安全裕度
Safety margins per thermal class

电气特性

Electrical design

运行环境

根据 IEC 60034-1 规定，容差是指测试值与铭牌 (或样本) 标称值之间的最大允许偏差。测试结果基于按照 IEC 60034-2-1, IEC 60034-9, IEC 60034-12 所规定的测试。

Environmental

In accordance with IEC 60034-1, tolerance is the maximum allowed deviation between the test result and the declared value on the rating plate (or in the catalog). Test results are based on test procedures in accordance with IEC 60034-2-1, IEC 60034-9, and IEC 60034-12.

过载倍数

根据 IEC 60034, M2BAX 系列电机能够在额定电压和频率下承受 1.5 倍的额定电流达 2 分钟。

Overload times

According to IEC 60034, M2BAX motors are designed to withstand overload capacity of 1.5 times rated current for 2 minutes at rated voltage and frequency.

电气数据容差

Tolerance for electrical data

	效率 Efficiency	功率因数* Power factor	启动电流 Locked rotor current I_s / I_N	堵转转矩 Locked rotor torque T_l / T_N	最大转矩 Breakdown torque T_b / T_N	转动惯量 Moment of inertia	噪声等级 Noise level
PN (kW) ≤ 150	-15 % (1-η)	-1/6 (1-cosφ)	+20 % of the current	[-15 % + 25 %] of the torque	-10 % of the value	± 10 % of the value	+3 dB(A)
PN (kW) > 150	-10 % (1-η)						
	转差率 Slip						
PN (kW) < 1	± 30 %						
PN (kW) < 1	± 20 %						

* 功率因数容差最小绝对值: 0.02, 最大绝对值: 0.07。

* Power factor minimum absolute value 0.02, maximum absolute value 0.07.

环境温度及海拔高度

标准电机设计的最大环境温度为 40°C, 最高海拔为 1000m。如果当电机在较高的环境温度或海拔下运行, 输出功率相应降低。详情请咨询 ABB。

Ambient temperatures and high altitudes

Normal motors are designed for operation at a maximum ambient temperature of 40 °C and at a maximum altitude of 1000 meters above sea level. If a motor is operated at higher ambient temperatures or altitude, it should be derated. Detailed information, please contact your ABB sales office.

对于不同高度和 (或) 不同环境温度的功率换算系数 kHT

Factor kHT for different site altitudes and / or coolant temperature

海拔高度 Site altitude above see level	对应海拔高度的环境温度 Site altitude above see level coolant temperature					
	< 30°C	30 ~ 40°C	45°C	50°C	55°C	60°C
1000 m	1.07	1.00	0.96	0.92	0.87	0.82
1500 m	1.04	0.97	0.93	0.89	0.84	0.79
2000 m	1.00	0.94	0.90	0.86	0.82	0.77
2500 m	0.96	0.90	0.86	0.83	0.78	0.74
3000 m	0.92	0.86	0.82	0.79	0.75	0.70
3500 m	0.88	0.82	0.79	0.75	0.71	0.67
4000 m	0.82	0.77	0.74	0.71	0.67	0.63

机械设计

Mechanical design

机座

包括底脚在内的电机机座是铸铁制成的。整体式铸铁底脚能够实现稳固的安装及最大程度的降低振动。可提供底脚安装型、凸缘安装型及二者结合的电机。

排水孔

如果在非常湿润或潮湿的环境下,特别是在断续负载下操作电机,则应设置排水孔。根据电机安装方法,指定相应的IM标号,如IM 3031。

机座号为71到355的电机安装了排水孔及闭合塞。孔塞在出厂时打开。安装电机时,确保排水孔朝下。

垂直安装时,上塞必须完全闭合。在灰尘过多的环境中,两个塞都应闭合。

安装方式不同于底脚安装型IM B3时,请在订购时使用变量代码066。

请参阅“排水孔”标题下的变量代码066。

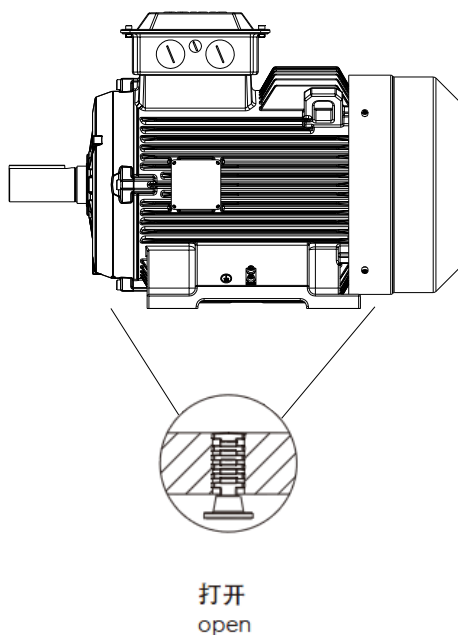

Motor frame

The motor frame is made of cast iron, and the standard design includes cast iron feet. Integrated cast iron feet provide rigid mounting, and minimize vibration. Motors can be supplied for foot mounting, flange mounting, and combinations of these.

Drain holes

Motors that will be operated in very humid or wet environments, and especially under intermittent duty, should be provided with drain holes. The IM designation, such as IM 3031, determines the intended mounting arrangement for the motor.

Motor sizes 71 - 355 are fitted with drain holes and closable plugs. The plugs are open on delivery. When mounting the motors, ensure that the drain holes face downwards.

In the case of vertical mounting, the upper plug must be hammered home completely. In very dusty environments, both plugs should be hammered home.

When mounting arrangement differs from foot mounted IM B3, mention variant code 066 when ordering.

See variant codes 066 under the heading “Drain holes”.

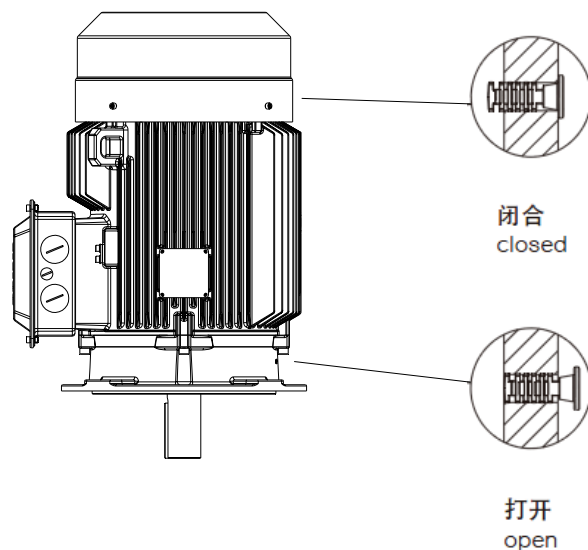

机座号 71-355
标准情况下配备排水孔及闭合塞

As standard, motor sizes 71 - 355 are delivered with drain holes and closable plugs.

机械设计

Mechanical design

轴承

电机通常安装以下单列深沟球轴承。

标准及可选设计

机座号	极数	标准设计	
		深沟球轴承	
		D 端	N 端
71	2-6	6203-2Z/C3	6202-2Z/C3
80	2-6	6204-2Z/C3	6203-2Z/C3
90	2-6	6205-2Z/C3	6204-2Z/C3
100	2-6	6206-2Z/C3	6205-2Z/C3
112	2-6	6206-2Z/C3	6205-2Z/C3
132	2-6	6208-2Z/C3	6208-2Z/C3
160	2-6	6209-2Z/C3	6209-2Z/C3
180	2-6	6210-2Z/C3	6209-2Z/C3
200	2-6	6212-2Z/C3	6209-2Z/C3
225	2-6	6213-2Z/C3	6210-2Z/C3
250	2-6	6215-2Z/C3	6212-2Z/C3
280 (IE2)	2-6	6217/C3	6316/C3
280 (IE3)	2-6	6217/C3	6217/C3
	2	6217/C3	6217/C3
315	4-6	6219/C3	6219/C3
	2	6219/C3	6219/C3
355	4-6	6222/C3	6222/C3

说明：

电机铭牌上显示轴承型号及描述方式仅供客户更换、维修轴承作参考，不代表轴承品牌，具体的轴承品牌以公司实际使用的为准。

轴向锁定轴承

所有电机在 D 端标配轴向锁定轴承。

Bearings

General performance motors are normally fitted with single-row deep-groove ball bearings, as shown in the table below.

Standard and alternative designs

Motor size	Number of poles	Standard design	
		Deep groove ball bearings	
		D-end	N-end
71	2-6	6203-2Z/C3	6202-2Z/C3
80	2-6	6204-2Z/C3	6203-2Z/C3
90	2-6	6205-2Z/C3	6204-2Z/C3
100	2-6	6206-2Z/C3	6205-2Z/C3
112	2-6	6206-2Z/C3	6205-2Z/C3
132	2-6	6208-2Z/C3	6208-2Z/C3
160	2-6	6209-2Z/C3	6209-2Z/C3
180	2-6	6210-2Z/C3	6209-2Z/C3
200	2-6	6212-2Z/C3	6209-2Z/C3
225	2-6	6213-2Z/C3	6210-2Z/C3
250	2-6	6215-2Z/C3	6212-2Z/C3
280 (IE2)	2-6	6217/C3	6316/C3
280 (IE3)	2-6	6217/C3	6217/C3
	2	6217/C3	6217/C3
315	4-6	6219/C3	6219/C3
	2	6219/C3	6219/C3
355	4-6	6222/C3	6222/C3

Remark:

The bearing type and description on rating plate do not represent the bearing brand, instead it is a technical consideration that can help the owner to make replacement and set up a maintenance program. The brand is subject to the bearing installed.

Axially-locked bearings

All motors are equipped as standard with an axially locked bearing. General at D-end.

机械设计

Mechanical design

轴密封件

机座号为 71-355 的密封件尺寸和类型符合下表：

Bearing seals

This table presents the standard sizes and types of bearing seals per motor size.

机座号 Motor size	极数 Number of Poles	标准设计 Standard design		可选设计 Optional design	
		轴向密封件 Axial seal		D 端伽玛密封 Gamma seal at D-end	D 端径向密封 Radial seal at D-end
		D 端 D-end	N 端 N-end	变量代码 784 Variant codes 784	变量代码 072 Variant codes 072
71	2-6	V-16A	V-14A	17 x 32 x 4	17 x 35 x7
80	2-6	V-20A	V-16A	20 x 35 x 4	20 x 40 x7
90	2-6	V-25A	V-20A	25 x 40 x 4	25 x 42 x7
100	2-6	V-30A	V-25A	30 x 47 x 4.5	30 x 52 x 7
112	2-6	V-30A	V-25A	30 x 47 x 4.5	30 x 52 x 7
132	2-6	V-40A	V-40A	40 x 57 x 4.5	40 x 62 x 7
160	2-6	V-45A	V-45A	45 x 62 x 4.5	45 x 72 x 8
180	2-6	V-50A	V-45A	50 x 70 x 4.5	50 x 80 x 8
200	2-6	V-60A	V-45A	60 x 80 x 4.5	60 x 85 x 8
225	2-6	V-65A	V-50A	65 x 85 x 4.5	65 x 90 x 10
250	2-6	V-75A	V-60A	75 x 95 x 4.5	75 x 100 x 10
280 (IE2)	2	VS85	VS80	85 x 105 x 5.5	NA
	4-6	VS85	VS80	85 x 105 x 5.5	85 x 110 x 12
280 (IE3)	2	VS85	VS85	85 x 105 x 5.5	NA
	4-6	VS85	VS85	85 x 105 x 5.5	85 x 110 x 12
315	2	VS85	VS85	85 x 105 x 5.5	NA
	4-6	VS85	VS85	95 x 115 x 5.5	95 x 120 x 12
355	2	VS85	VS95	95 x 115 x 5.5	NA
	4-6	VS110	VS95	110 x 130 x 5.5	NA

机械设计

Mechanical design

轴承寿命

根据 ISO 281, 轴承的正常寿命 L_{10h} 定义为在特定条件下 90% 的相同轴承在一系列测试中所达到或超过的运行小时数。50% 的轴承至少达到这一数字的五倍。

润滑

装有永久润滑轴承的电机

机座号为 71-250 的电机采用永久润滑轴承。永久润滑轴承中装有优质的润滑脂。铭牌上印有轴承型号。

以下数值可作为轴承使用寿命指导值, 具体寿命取决于应用和负载情况: 2-6 极电机约为 40,000 小时

皮带轮直径

所需轴承寿命确定后, 最小允许皮带轮直径可使用 F_R 计算, 如下所示:

$$D = \frac{1.9 \cdot 107 \cdot K \cdot P}{n \cdot F_R}$$

其中:

D:	带轮直径, 单位 (mm)
P:	功率要求, kW
n:	电机转速, r/min
K:	皮带张力因数, 取决于皮带类型和负载类型。 V 形皮带通用值为 2.5。
F_R :	允许径向力

Bearing life

The nominal life L_{10h} of a bearing is defined according to ISO 281 as the number of operating hours achieved or exceeded by 90% of identical bearings in a large test series under specified conditions. 50% of bearings achieve at least five times this lifetime.

Lubrication

Motors with bearings greased for life

Motors in frame sizes 71-250 are equipped with bearings greased for life. Bearings are lubricated with high-quality grease. Bearing types are stated on the rating plate.

The following values can be used as a guide for bearing lifetime, depending on application and load conditions: 2-6 pole motors about 40,000h.

Pulley diameter

When the desired bearing life has been determined, the minimum permissible pulley diameter can be calculated with F_R as follows:

$$D = \frac{1.9 \cdot 107 \cdot K \cdot P}{n \cdot F_R}$$

Where:

D:	Pulley diameter, mm
P:	Power requirement, kW
n:	Motor speed, r/min
K:	Belt tension factor, dependent on belt type and type of duty A common value of V-belts is 2.5
F_R :	Permissible radial force

机械设计

Mechanical design

轴上允许负载

允许轴向力

表中提供了环境温度为 25°C 时，50Hz 的正常条件下，径向力为零时的轴伸允许轴向力 (N)。分别对轴承寿命满足 20000 和 40000 小时进行计算。

在 60 Hz 时，数值将相应减少 10%。对于双速电机，数值将以较高的速度为准。

需提供同时存在径向力和轴向力的允许负载值，请联系 ABB。

给定轴向力 F_{AD} ，假设 D 端轴承由锁环锁定。

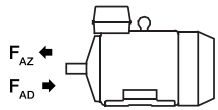

安装方式 IM B3

Permissible loading on the shaft

Permissible axial forces

The following table gives the permissible axial forces on shaft in Newton, assuming zero radial force, ambient temperature of 25°C, and normal conditions at 50Hz. The values are given for calculated bearing life of 20000 and 40000 hours per motor size.

At 60 Hz, the values must be reduced by 10 percent, and for two-speed motors, the higher speed determines permissible axial force. Permissible loads of simultaneous radial and axial forces can be supplied on request.

For axial force F_{AD} , it is assumed that the D-bearing is locked with a locking ring.

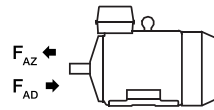

Mounting arrangement IM B3

机座号 Motor size	极数 No. of poles	轴伸长度 Length of shaft extension E (mm)	深沟球轴承 Basic design with deep groove ball bearings			
			20,000小时 20,000 h		40,000小时 40,000 h	
			F_{AD} (N)	F_{AZ} (N)	F_{AD} (N)	F_{AZ} (N)
71	2	30	580	300	465	185
	4	30	725	445	580	300
	6	30	810	530	670	390
80	2	40	750	430	595	275
	4	40	940	620	750	430
	6	40	1055	735	870	550
90	2	50	845	445	675	275
	4	50	1050	650	840	440
	6	50	1175	775	935	535
100	2	60	1175	615	940	380
	4	60	1465	905	1175	615
	6	60	1640	1080	1305	745
112	2	60	1175	615	935	375
	4	60	1460	900	1170	610
	6	60	1635	1075	1300	740
132	2	80	1675	795	1415	535
	4	80	2110	1230	1665	785
	6	80	2450	1570	1950	1070
160	2	110	1665	1205	1300	840
	4	110	2135	1675	1650	1190
	6	110	2465	2005	1895	1435

机座号 Motor size	极数 No. of poles	轴伸长度 Length of shaft extension E (mm)	深沟球轴承 Basic design with deep groove ball bearings			
			20,000小时 20,000 h		40,000小时 40,000 h	
			F_{AD} (N)	F_{AZ} (N)	F_{AD} (N)	F_{AZ} (N)
180	2	110	1730	1275	1345	890
	4	110	2215	1755	1705	1245
	6	110	2590	2130	1990	1530
200	2	110	2240	1780	1725	1265
	4	110	2900	2445	2215	1755
	6	110	3400	2945	2595	2135
225	2	110	2440	2210	1845	1615
	4	140	3195	2965	2395	2170
	6	140	3745	3520	2810	2580
250	2	140	2860	2620	2155	1920
	4	140	3765	3525	2825	2585
	6	140	4420	4180	3310	3070
280	2	140	4360	2360	3490	1490
	4	140	5475	3475	4310	2310
	6	140	6320	4320	4945	2945
315	2	140	4180	2180	3325	1325
	4	170	6750	4750	5220	3220
	6	170	7700	5700	5900	3900
355	2	140	5020	3305	3890	2180
	4	210	8030	6320	6090	4375
	6	210	9315	7605	7015	5300

机械设计

Mechanical design

允许径向力

表中提供了环境温度为 25°C 时，50Hz 的正常条件下，轴向力为零时的轴伸允许径向力 (N)。分别对轴承寿命满足 20,000 小时和 40,000 小时进行计算。

电机为底座安装型 IM B3，并且含横向力。在某些情况下，轴的强度影响允许负载力。在 60Hz 时，数值将相应减少 10%。对于双速电机，数值应以较高的速度为准。

需提供同时存在径向力和轴向力的允许负载值，请联系 ABB。

如果径向力作用于点 X_0 和 X_{max} 之间，则允许负载力 F_R 可以通过以下公式计算：

$$F_R = F_{X_0} - \frac{X}{E} (F_{X_0} - F_{X_{max}})$$

E：基本型号中的轴伸长度

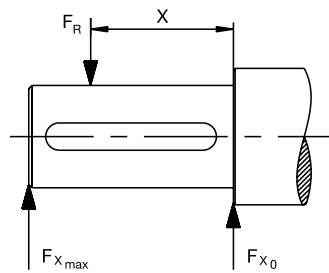

机座号 Motor size	极数 No. of poles	轴伸长度 Length of shaft extension E (mm)	深沟球轴承 Basic design with deep groove ball bearings			
			20,000小时 20,000 h		40,000小时 40,000 h	
			F_{X_0} (N)	$F_{X_{max}}$ (N)	F_{X_0} (N)	$F_{X_{max}}$ (N)
71	2	30	545	465	430	370
	4	30	685	585	545	465
	6	30	785	660	620	530
80	2	40	740	620	585	490
	4	40	925	775	730	615
	6	40	1065	890	840	705
90S	2	50	795	645	625	510
	4	50	1000	815	790	645
	6	50	1145	935	905	740
90L	2	50	795	660	630	520
	4	50	1005	830	790	655
	6	50	1150	950	910	750
100	2	60	1110	895	875	705
	4	60	1395	1120	1100	885
	6	60	1605	1290	1265	1020
112	2	60	1120	925	885	730
	4	60	1405	1160	1105	915
	6	60	1615	1335	1275	1050
132S	2	80	1630	1270	1285	1000
	4	80	2055	1600	1620	1260
	6	80	2360	1840	1860	1450
132M	4	80	2075	1665	1630	1310
	6	80	2375	1905	1865	1495
	160	2	110	1945	1510	1545
4		110	2455	1905	1945	1510
6		110	2835	2250	2245	1780

Permissible radial forces

The following table gives the permissible radial forces on shaft in Newton, assuming zero axial force, ambient temperature of 25°C, and normal conditions at 50Hz. The values are given for calculated bearing life of 20,000 and 40,000 hours per motor size.

These calculated values further assume mounting position IM B3 (foot-mounted), with force directed sideways. In some cases, the strength of the shaft affects permissible forces.

Permissible loads of simultaneous radial and axial forces can be supplied on request.

If the radial force is applied between points X_0 and X_{max} , the permissible force F_R can be calculated with the following formula:

$$F_R = F_{X_0} - \frac{X}{E} (F_{X_0} - F_{X_{max}})$$

E：Length of the shaft extension in the standard version

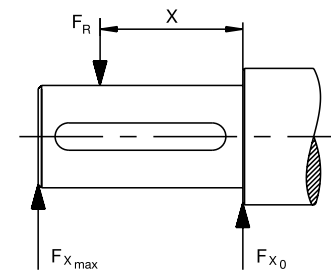

机座号 Motor size	极数 No. of poles	轴伸长度 Length of shaft extension E (mm)	深沟球轴承 Basic design with deep groove ball bearings			
			20,000小时 20,000 h		40,000小时 40,000 h	
			F_{X_0} (N)	$F_{X_{max}}$ (N)	F_{X_0} (N)	$F_{X_{max}}$ (N)
180	2	110	2095	1705	1660	1350
	4	110	2640	2145	2090	1700
	6	110	3025	2460	2395	1950
200	2	110	2815	2310	2230	1830
	4	110	3550	2910	2810	2305
	6	110	4065	3335	3220	2640
225	2	110	3335	2795	2640	2215
	4	140	4200	3370	3325	2670
	6	140	4810	3860	3805	3055
250	2	140	3965	3220	3140	2550
	4	140	4995	4060	3955	3215
	6	140	5715	4645	4525	3675
280S	2	140	4855	3960	3840	3135
	4	140	6120	4995	4840	3955
	6	140	7000	5715	5540	4525
280SM	2	140	4900	4075	3875	3225
	4	140	6180	5140	4885	4065
315SM	2	140	4900	4180	3855	3285
	4	170	8120	6715	6415	5300
	6	170	9270	7660	7305	6040
315ML	2	140	4925	4275	3860	3350
	4	170	8185	6910	6450	5445
	6	170	9335	7885	7340	6200
355SM	2	140	6365	5585	4980	4370
	4	210	10530	8700	8260	6825
	6	210	12050	9955	9445	7805

机械设计

Mechanical design

标准接线盒交付

标准接线盒的防护等级为 IP55。标准情况下，接线盒安装在电机 D 端顶部。此外，还可以将接线盒安装在左侧或右侧，请参考订购信息。机座号 71-132 的电机，采用一体式接线盒。机座号 160-355 的电机，采用分体式接线盒。

机座号为 160-355 的电机接线盒可 4x90° 转动。因此电机的两侧都可以接入电缆。但对于机座号为 71-132 的标准电机，接线盒无法转动，如需实现接线盒电缆入口 2x180° 转向，可使用变型代码 (VC022)。

如果未另行规定，则采用标准交付。

注意：对于 500V 及 / 或侧面安装的电机，请联系 ABB！

Standard terminal box

The degree of protection for the standard terminal box is IP 55. By default, terminal boxes are mounted on top of the motor at D-end. In motor sizes 71-132, the terminal box is integrated in motor frame. In motor sizes 160-355, the terminal box is separate from motor frame.

The terminal boxes of motor sizes 160-355 can be turned 4x90°, to allow cable entry from either side of motor. For motor sizes 71-132, turning is not possible in the standard motor, but 2x180° turning is available as an option (variant code 022).

Standard delivery if no other information is provided.

Note: For other network voltages and/or side-mounted motors, contact your ABB sales office.

机座号 Motor size	极数 Pole number	螺纹孔 Threaded holes	电缆外径 mm Cable outer diameter mm	单芯横截面 平方毫米/相 Single core cross-section mm ² /phase	端子螺栓尺寸 6x terminal bolt size 6x
71	2-6	2xM16x1.5	Ø5-9	2.5	M4
80-90	2-6	2xM25x1.5	Ø11-16	4	M4
100-132	2-6	2xM32x1.5	Ø14-21	10	M5
160-200	2-6	2xM40x1.5+M16x1.5	Ø19-27	35	M6
225-250	2-6	2xM63x1.5+M16x1.5	Ø34-45	70	M10
280	2-6	2xM63x1.5, 2xM20x1.5	2xØ32-49, Ø8-14	2x150	M10 (IE2) ; M12 (IE3)
315	2-6	2xM63x1.5, 2xM20x1.5	2xØ32-49, Ø8-14	2x240	M12
355	2-6	2xM75x1.5, 2xM20x1.5	2xØ48-60, Ø8-14	4x240	M12

电机接地 Earthing	机座接地 Earthing on frame	主接线盒接地 Earthing in main terminal box
71-132	M5	M5
160-250	M6	M6
280-355	M10	M10

变频器驱动

Variable speed drives

鼠笼式感应电机具有无与伦比的可用性、可靠性与效率。通过变频器——一种变速驱动器（VSD），该电机的性能将更优异。电机不是一直处于全速运转状态，相反，变速驱动器能够根据实际需要调节速度。这样，就能够准确地控制工艺过程，在某些情况下，甚至可以达到比标称速度更快的运转速度，从而提高产能。

与传统的全压启动（DOL）不同，变速驱动器（VSD）能够平滑地进行启动。这样就大大地减少了电机及驱动应用中的压力。平滑启动还意味着供电网络不受高启动电流的影响。在电网设计时，应将该因素纳入考虑。

由于在速度和工艺用电方面的优化，ABB 低压一般用途电机以及变频器的使用，尤其是 ABB 变频器的使用，通常能够在很大程度上实现节能。节能不仅能够产生环境效益，还能够带来经济效益。ABB 低压一般用途电机适用于 DOL 运行，也适用于变速运行。选择面广，电机能够适应甚至是最苛刻的应用要求。

在为变速驱动器选择低压一般用途电机时，应考虑以下方面：

1. 确定规格

变频器所馈送的电压（或电流）并非完全是正弦的。这可能会增加电机的损耗、振动以及噪音等级。此外，这些损耗分布的变化可能影响电机的温升。因此，在任何情况下，需要根据特定的变频器说明书正确选择电机规格。

使用 ABB 变频器时，请使用 ABB 的 DriveSize 程序来确定电机规格。该工具利用的是基本综合性组合型式试验的规格确定规则。

当手动确定规格时，请注意，此目录中以及相关手册中给出的负载率（负载能力）曲线仅供参考。可根据要求提供针对各个电机和变频器的精确数值。除确定热容量外，必须保持一个转矩裕度，以保持稳定。电机的最大转矩在整个工作周期内应至少高于负载转矩 30%。

尤其是在使用较长的供电电缆时，还必须考虑供电电缆的压降。

Squirrel cage induction motors offer excellent availability, reliability and efficiency. With a variable speed drive (VSD) – a frequency converter – the motor performance can be further improved. Instead of running the motor continuously at full speed, the VSD enables speed adjustment according to actual need. The VSD makes it possible to control the process accurately and in some cases even to improve the capacity of the process by operating at higher than nominal speeds.

In contrast with conventional applications operating with a direct-on-line (DOL) supply, a VSD makes smooth starting possible. This significantly reduces the stress on the motor and driven application. Smooth starting also means that the supply network will not be affected by high starting current transients, a fact that can be taken into account in the design of the network.

The use of ABB industrial drives together with General performance motors usually provides substantial energy savings as the speed and therefore the power required by the process can be optimized. General performance motors are designed for both DOL and variable speed operation. A wide range of options is available, so motors can be adapted to the most demanding applications.

When selecting general performance motors for VSDs, the following points must be taken into consideration.

1. Dimensioning

The voltage (or current) fed by the VSD is not purely sinusoidal. This may increase motor losses, vibration, and noise level. Further, a change in the distribution of losses may affect the motor's temperature rise. In each case, the motor must be correctly sized according to the instructions supplied for the frequency converter.

ABB's DriveSize program utilizes dimensioning rules that are based on comprehensive motor and drive type tests. Please use DriveSize for selecting the correct motor and drive combination for a desired load profile.

In case of manual dimensioning, note that the loadability (or load capacity) curves provided in this catalog and in the respective manuals are indicative only. Values for a specific motor and drive are available on request. In addition to thermal dimensioning, an adequate torque margin must be maintained for stability. The maximum torque of the motor must be at least 30 % higher than the load torque over the whole duty range.

Voltage drop in the supply cable must also be taken into consideration, especially in cases where long supply cables are needed.

2. 工作转速、振动及轴密封

低压一般用途电机设计可以在宽转速范围内工作，在大多数情况下，也可以显著高于额定转速（即铭牌上印制的转速）的较高转速运行可以通过铭牌或 DriveSize 工具获知最大转速。除电机转速范围外，请确保不超出整个应用的最大或临界转速。

下表 1 给出了低压一般用途电机的最大规定转速值。

表 1 低压一般用途电机的最大规定转速值

机座号	转速 r/min	
	2 电极	4 电极
71-80	6000	4500
90-100	6000	6000
112-200	4500	4500
225-250	3600	3600
280	3600	2600
315	3600	2300
355 SM	3600	2000

3. 通风

电机低速运行时，风扇的冷却能力下降，进而降低电机的负载能力。可以另外使用一个独立的恒速风扇（变量代码 183）来提升冷却能力。

高速运行时，应考虑使用金属风扇在（变量代码 068），而不是塑料风扇。

4. 润滑

在变速应用场合中，轴承温度的变化是由于速度和电机负载变化的结果。这时，在正常工作条件下，通过测量轴承温度，可以得到最精确的润滑间隔时间。如果测量温度高于 +80°C，则需要缩短在润滑铭牌或电机手册中规定的润滑间隔时间，或使用适用于高温工况的润滑脂。请参见 ABB 低压电机手册。

在非常低的速度和温度（低于 20°C）下连续工作时，标准润滑脂的润滑能力可能不足，而需要使用含添加剂的特定润滑脂。更多详情，请联系 ABB。

如果电机配备密封轴承，即一次性润滑轴承，则务必注意，当工作温度与设计温度不同时，轴承的工作寿命也会与设计值不同。有关轴承工作寿命的详细信息，请参见本目录及相关手册中与产品相关的章节。

我们不建议使用所谓的导电润滑脂来消除轴承电流，因为此类产品的润滑性能不良，因此导电性很弱。

2. Operating speed, vibrations and shaft seals

General performance motors are designed to work over a wide speed range and also at significantly higher than nominal speeds. The maximum speeds can be found on motor rating plates or in DriveSize. In addition to motor speed, make sure that the maximum or critical speed of the entire application is not exceeded.

Guideline maximum speed values for general performance motors are shown in Table 1.

Table 1. Guideline maximum speed values for general performance cast iron motors.

Motor size	Maximum speed, r/min	
	2-pole motors	4-pole motors
71-80	6000	4500
90-100	6000	6000
112-200	4500	4500
225-250	3600	3600
280	3600	2600
315	3600	2300
355 SM	3600	2000

3. Ventilation

When the motor is operated at low speeds, the cooling capacity of the fan decreases, which again reduces the motor's load capacity. A separate constant speed fan (variant codes 183) can be used to increase cooling capacity.

At high speeds, the use of metal fans (variant code 068) instead of plastic ones should be considered.

4. Lubrication

In variable speed applications, bearing temperature varies as a function of speed and motor load. In such cases, the most accurate relubrication intervals can be obtained by measuring the bearing temperature under normal operating conditions. If the measured temperature is higher than +80°C, the relubrication intervals specified on the lubrication plate or in the maintenance manual must be shortened, or lubricants suitable for high operating temperatures must be used. See ABB Low voltage motor manual.

In case of continuous operation at very low speeds and at very low temperatures (below -20°C), the lubrication properties of standard greases may not be sufficient, and special greases with additives are needed.

Operating temperatures also affect bearing life. When motors are equipped with sealed bearings, that is, bearings greased for life, it must be noted that if the operating temperature differs from the design temperature, the bearing life will also be different. More information on bearing lifetimes can be found in section Mechanical design of this catalog and in the relevant manuals.

The use of so-called conductive greases for elimination of bearing currents is not recommended because of their poor lubrication characteristics and low conductivity.

5. 绕组绝缘

为确保电机的可靠性，当为电机选择正确的绝缘系统和为变频器选择正确的输出滤波器时，必须考虑变频器的非正弦输出电压的影响。

当使用具有非受控直流电压的变频器时，应根据表 2 选择绝缘和滤波器。

表 2 变频器（其具有非受控直流电压）电机的绕组绝缘及变频器输出滤波器选择

所要求的绕组绝缘和滤波器	
$U_N \leq 500V$	ABB 变频绝缘
$U_N \leq 600V$	ABB 变频绝缘 +dU/dt 滤波器 或 ABB 变频加强绝缘（变量代码 405）
$U_N \leq 690V$	ABB 变频加强绝缘（变量代码 405） 及 变频器输出端的 dU/dt 滤波器
$600V < U_N \leq 690V$	ABB 变频加强绝缘（变量代码 405）

GB14711-2013 新增变频电源供电绝缘结构要求

dU/dt 滤波器的详细信息，请参见相关的 ABB 驱动目录。

如果表 2 中的内容不适用，以及对于其它类型的变频器，则应根据电机端子电压进行选择。

电机端子处允许的相对地电压峰值为：

- ABB 变频绝缘 1300V
- ABB 变频加强绝缘（变量代码 405）1800V

受脉冲上升时间的影响，电机端子处允许的最大相对地电压峰值见图 1。最高的曲线（即“ABB 变频加强绝缘”）适用于变频器电源采用特殊绕组绝缘的电机，变量代码为 405。“ABB 变频绝缘”适用于具有标准设计的电机。

图 1 受脉冲上升时间的影响，电机端子处允许的最大相对地电压峰值

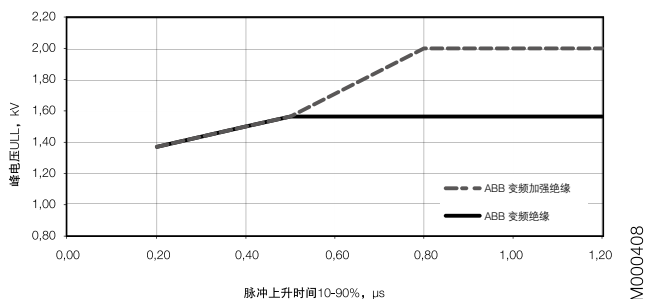

5. Winding insulation

To ensure that motors operate reliably, the effects of non-sinusoidal output voltages from the converter must be taken into consideration when selecting the correct insulation system for the motor and output filters for the converter.

Insulation and filters must be selected according to Table 2.

Table 2. Selection of motor winding insulation and converter output filters

Winding insulation and filters required	
$U_N \leq 500V$	VSD insulation
$U_N \leq 600V$	VSD insulation + dU/dt filters OR VSD reinforced insulation (variant code 405)
$U_N \leq 690V$	VSD reinforced insulation (variant code 405) AND dU/dt filters at converter output
$600V < U_N \leq 690V$	VSD reinforced insulation (variant code 405)

GB14711-2013 added insulation specification for frequency converter

For more information on dU/dt filters, see the relevant ABB Drives catalogs.

For other converters and cases where the guidelines shown in Table 2 cannot be applied, selection must be based on the voltages present at motor terminals.

The allowed phase-to-ground voltage peaks at motor terminals:

- 1300 V peak: VSD insulation
- 1800 V peak: VSD reinforced insulation, variant code 405

The maximum allowed phase-to-phase voltage peaks at the motor terminals as a function of pulse rise time are shown in Figure 1. The higher curve, VSD reinforced insulation, applies to motors with special winding insulation for frequency converter supply, variant code 405. VSD insulation applies to motors with standard design.

Figure 1. Maximum allowed phase-to-phase voltage peaks at motor terminals, as a function pulse rise time.

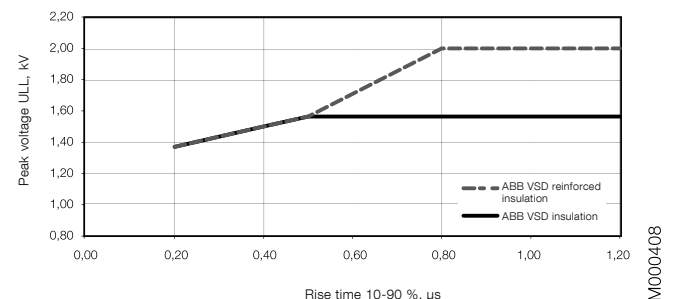

6. 轴承电流

必须在所有电机中消除轴承电压和电流，确保整项工作的可靠开展。如果使用具有非受控直流电压的 ABB ACS800 或 ACS550 驱动器，则必须按照下表 3 所示，使用绝缘轴承（变量代码 701）和/或在变频器输出上加上适当规格的滤波器。有关其它代替产品和变频器类型，请联系 ABB。订购时，请明确注明将使用的代替产品。

有关轴承电流和电压的详细资料，请参见“AC 驱动系统中的轴承电流”工厂文件或联系 ABB。

表 3 与变频器（其具有非受控直流电压）配合使用的电机中的轴承电流防护。

标称功率 (P_N) 及 / 或机座号 (IEC)	防护措施
$P_N \leq 100$ kW	无需采取措施
$P_N \geq 100$ kW 或 IEC 315 \leq 机座号 \leq IEC 355	非驱动端绝缘轴承
$P_N \geq 350$ kW	非驱动端绝缘轴承，关在变频器中设置共模滤波器

共模滤波器

共模滤波器减少了共模电流，从而减少了出现轴承电流的风险。共模滤波器不会严重影响电机接线端子的相电压或电源电压。更多详情，请参见 ABB 驱动器目录。

绝缘轴承

ABB 使用带绝缘内圈或外圈的轴承。所谓混合轴承，也就是带非导电性陶瓷滚动元件的轴承，也可用于特定用途。

7. 电缆敷设、接地及 EMC

变频器对驱动系统的电缆铺设和接地提出了更高的要求。应使用屏蔽对称电缆和提供 360° 接头的电缆接头（也称为 EMC 接头，变量代码 704）来连接电机。对于输出功率不高于 30kW 的电机，可使用非对称电缆，但始终建议使用屏蔽电缆，尤其在驱动应用中存在敏感部件时。

对于机座号为 IEC 280 及以上的电机，除非在一个公共的金属底座上安装电机和驱动机器，否则需要在电机机座和机器之间另外进行电位均衡处理。当使用一个金属底座来实现电位均衡时，应检查此连接的高频导电性。有关变速驱动器的接地和电缆敷设的更多信息，请参见手册“驱动系统的接地和电缆敷设”（编号：3AFY 61201998 R0125 REV B）。

为满足 EMC 的要求，除安装正确的电缆接头外，还必须使用专用的 EMC 电缆（另外具有专用接地件）。请参见变频器手册。

6. Bearing currents

Bearing voltages and currents must be avoided in all motors to ensure reliable operation of the entire application. With ACS800 or ACS550 drives and uncontrolled DC voltage, insulated bearings (variant code 701) and/or properly dimensioned filters at the converter must be used, as indicated in Table 3.

For information on other converter types, contact ABB Sales. When ordering, clearly state which alternative will be used.

Table 3. Precautionary measures to avoid bearing currents in variable speed drives.

Nominal Output (P_N) AND / OR Motor size (IEC)	Precautionary measures
$P_N \leq 100$ kW	No action needed
$P_N \geq 100$ kW OR IEC 315 \leq Frame size \leq IEC 355	Insulated non-drive end bearing
$P_N \geq 350$ kW	Insulated non-drive end bearing AND Common mode filter at the converter

Common mode filters

Common mode filters reduce common mode currents and so decrease the risk of bearing currents. Common mode filters do not significantly affect the phase of main voltages on motor terminals. For more information, see ABB drives catalogs.

Insulated bearings

ABB uses bearings with insulated inner or outer races. Hybrid bearings, that is, bearings with non-conductive ceramic rolling elements, can also be used in special applications.

7. Cabling, grounding, and EMC

The use of a variable speed drive sets higher demands on the cabling and grounding of the drive system. The motor must be cabled using shielded symmetrical cables and cable glands providing 360° bonding (EMC glands, variant code 704). For motors up to 30 kW, asymmetrical cables can be used, but shielded cables are always recommended, especially if there are sensitive components in the driven application.

For motor sizes IEC 280 and above, additional potential equalization is needed between the motor frame and the machinery, unless the motor and the driven machine are installed on a common steel base. When a steel base is used for potential equalization, high frequency conductivity of the connection must be checked.

To meet EMC requirements, special EMC cables must be used in addition to appropriate cable gland mounting with special earthing pieces. Refer to ABB drives manuals for more information.

8. 变频器的电机负载能力

图 2、图 3 所示的负载能力曲线具有指导意义。欲知精确数值，请联系 ABB。这些负载能力曲线还可以用于其它变频器的初步规格确定，但必须注意的是，不同变频器的谐波分量和控制算法互不相同，因此电机的温升也会不同。

8. Motor loadability with frequency converter drives

The loadability curves shown in Figures 2 and 3 are indicative guidelines and do not present exact values. These loadability curves can also be used for preliminary dimensioning of motors used at frequency converter duty, but it must be noted that the harmonic content and control algorithms vary between frequency converters, so the motor temperature rise will also be different.

图 2 具有 DTC 控制的变频器负载曲线

Figure 2. Loadability curves for frequency converters with DTC control

B 级温升

Temperature rise B

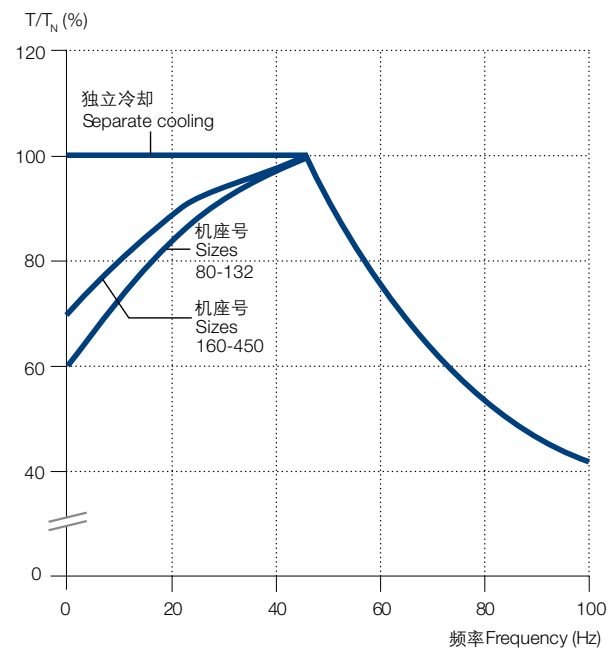

F 级温升

Temperature rise F



图 3 其它控制类型的变频器负载曲线

Figure 3. Loadability curves for other frequency converters

B 级温升

Temperature rise B

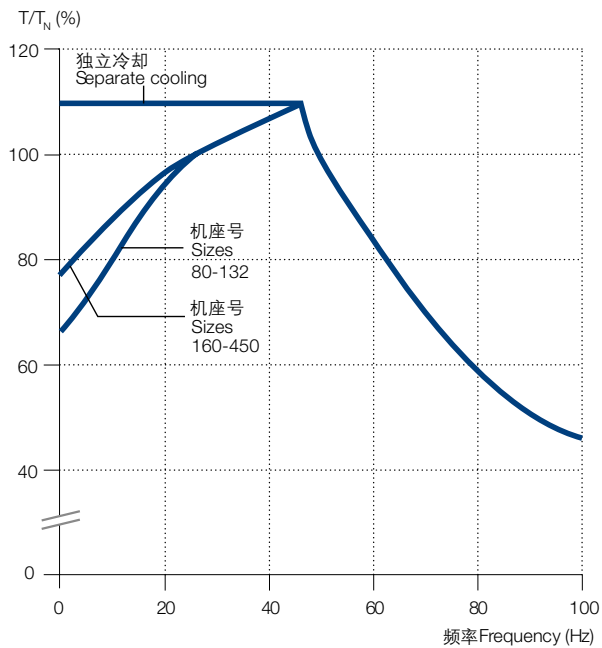
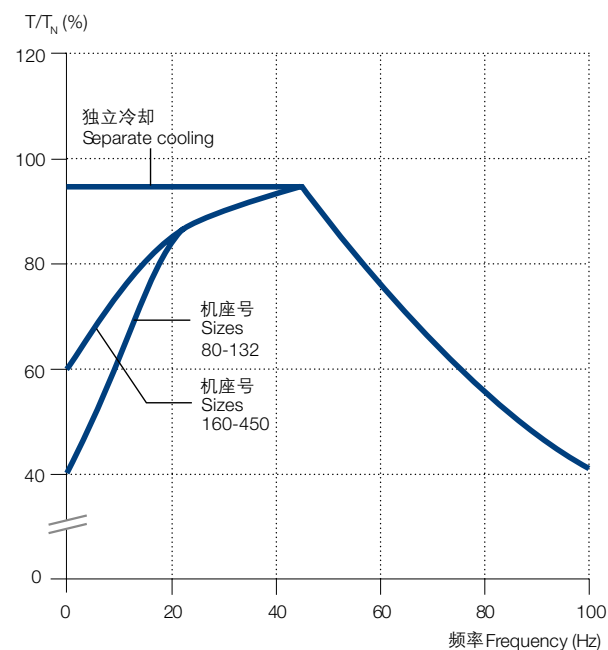

F 级温升

Temperature rise F

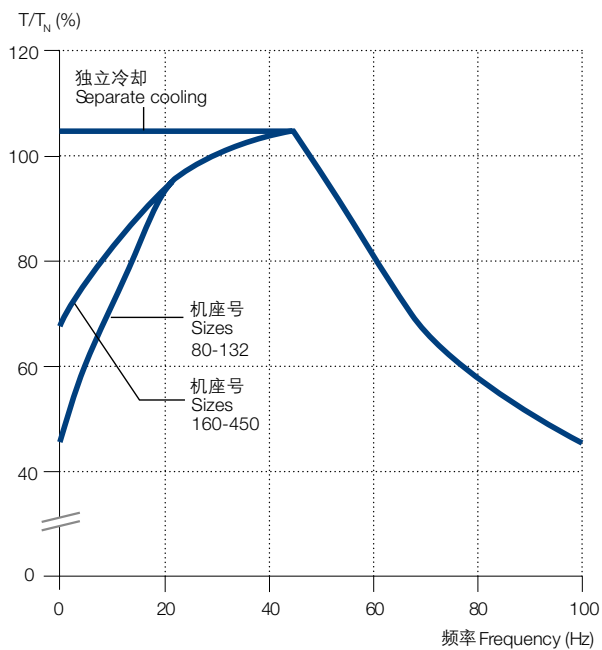

三相全封闭鼠笼式电机的技术数据

Technical data for totally enclosed squirrel cage three phase motors

IP 55 – IC 411 – 绝缘等级 F，温升等级 B

0.18-0.75kW，符合 GB 25958-2010 的 3 级能效

0.75-355kW，符合 IEC 60034-30-1; 2014 的 IE2 效率等级及 GB 18613-2012 的 3 级能效

IP 55 - IC 411 - Insulation class F, temperature rise class B

0.18-0.75kW, Grade 3 according to GB 25958-2010

0.75-355kW, IE2 efficiency class according to 60034-30-1; 2014, Grade 3 according to GB 18613-2012

输出 Output	电机型号 Motor type	产品代码 Product code	转速 Speed	效率 / Efficiency IEC 60034-2-1; 2007			功率 因数 Power factor cos φ	电流 Current			转矩 / Torque		转动惯量 Moment of inertia J=1/4 GD ² kgm ²	重量 Weight kg	声压等级 Sound pressure level, L _{PA} dB
				满载 load 100%	3/4 负载 load 75%	1/2 负载 load 50%		I _N A	I _s /I _N	T _N Nm	T _l /T _N	T _b /T _N			
3000 r/min = 2 极 / 2 poles			380 V 50Hz			CENELEC- 设计 design									
0.37	M2BAX 71 MA	3GBA 071 310-●●CCN	2769	73.5	73.0	70.3	0.84	0.91	4.9	1.26	2.5	3.0	0.00033	9	56
0.55	M2BAX 71 MB	3GBA 071 320-●●CCN	2790	75.5	75.3	73.1	0.83	1.33	5.2	1.86	2.8	3.2	0.00041	10	58
0.75	M2BAX 80 MA	3GBA 081 310-●●CCN	2797	77.4	76.5	76.2	0.86	1.71	5.3	2.51	2.7	3.9	0.00067	13	63
1.1	M2BAX 80 MB	3GBA 081 320-●●CCN	2821	79.6	80.2	79.8	0.87	2.41	5.2	3.67	2.8	3.7	0.00088	14	62
1.5	M2BAX 90 SA	3GBA 091 110-●●CCN	2876	81.3	80.6	78.6	0.84	3.34	6.7	4.93	2.8	3.5	0.00208	20	66
2.2	M2BAX 90 LA	3GBA 091 510-●●CCN	2882	83.2	83.6	82.9	0.88	4.57	7.1	7.25	2.8	3.4	0.00274	23	67
3	M2BAX 100 LA	3GBA 101 510-●●CCN	2894	84.6	85.2	84.1	0.93	5.79	7.1	9.90	2.6	3.4	0.00475	32	74
4	M2BAX 112 MA	3GBA 111 310-●●CCN	2878	85.8	87.0	86.9	0.94	7.54	7.0	13.3	2.4	3.2	0.00561	36	74
5.5	M2BAX 132 SA	3GBA 131 110-●●CCN	2908	87.0	86.5	84.8	0.89	10.8	7.6	18.0	2.3	3.8	0.01170	54	74
7.5	M2BAX 132 SB	3GBA 131 120-●●CCN	2905	88.1	87.7	86.7	0.88	14.7	8.1	24.6	2.7	4.0	0.01319	58	72
11	M2BAX 160 MLA	3GBA 161 410-●●CCN	2919	89.4	89.9	89.6	0.88	21.2	6.2	35.9	2.2	3.1	0.041	102	72
15	M2BAX 160 MLB	3GBA 161 420-●●CCN	2929	90.3	90.7	90.5	0.90	28.0	7.0	48.9	2.7	3.1	0.054	115	72
18.5	M2BAX 160 MLC	3GBA 161 430-●●CCN	2932	90.9	91.2	91.1	0.90	34.4	7.9	60.1	2.8	3.4	0.060	123	73
22	M2BAX 180 MLA	3GBA 181 410-●●CCN	2929	91.3	92.2	92.3	0.93	39.4	7.5	71.7	3.1	3.1	0.073	150	72
30	M2BAX 200 MLA	3GBA 201 410-●●CCN	2940	92.0	91.9	91.2	0.90	55.0	7.5	97.4	3.2	3.5	0.110	198	81
37	M2BAX 200 MLB	3GBA 201 420-●●CCN	2943	92.5	92.8	92.6	0.91	66.8	7.6	120	3.2	3.3	0.141	229	80
45	M2BAX 225 SMA	3GBA 221 210-●●CCN	2946	92.9	93.3	93.1	0.92	80.0	7.6	146	2.8	3.0	0.226	273	82
55	M2BAX 250 SMA	3GBA 251 210-●●CCN	2958	93.2	93.5	93.4	0.89	99.6	7.4	177	3.1	2.7	0.344	334	78
75	M2BAX 280 SMD	3GBA 281 240-●●HCN	2968	93.8	94.3	94.4	0.89	135	7.6	241	3.3	3.3	0.6	527	78
90	M2BAX 280 SME	3GBA 281 250-●●HCN	2971	94.1	94.5	94.6	0.91	158	7.2	290	3.6	3.1	0.7	576	76
110	M2BAX 315 SMA	3GBA 311 210-●●CCN	2981	94.3	94.0	92.8	0.84	211	6.7	352	2.0	2.9	1.2	767	78
132	M2BAX 315 SMB	3GBA 311 220-●●CCN	2979	94.6	94.5	93.6	0.86	247	6.9	423	2.1	2.8	1.4	827	78
160	M2BAX 315 SMC	3GBA 311 230-●●CCN	2979	95.1	95.0	94.3	0.90	284	6.8	512	2.1	2.7	1.7	917	78
200	M2BAX 315 MLA	3GBA 311 410-●●CCN	2978	95.0	95.1	94.4	0.89	359	7.1	641	2.6	2.6	2.1	1037	83
250	M2BAX 355 SMA	3GBA 351 210-●●CCN	2981	95.3	95.2	94.4	0.90	442	6.2	800	1.4	2.5	2.7	1329	83
315	M2BAX 355 SMB	3GBA 351 220-●●CCN	2978	95.4	95.4	94.8	0.89	563	6.5	1010	1.7	2.5	3.4	1469	83
355 ¹⁾	M2BAX 355 SMC	3GBA 351 230-●●CCN	2981	95.4	95.5	95.1	0.89	635	6.8	1137	1.9	2.4	3.6	1539	83

¹⁾ 温升等级 F ¹⁾ temperature rise class F

产品代码中的两个圆点表示可选的安装方式、电压及频率代码（见订购信息一页）。

The two bullets in the product code indicate choice of mounting arrangements, voltage and frequency code (see ordering information page).

根据 IEC 60034-2-1 edition 2.0, 2014-06 的要求，给出效率值。

请注意，在测试方法未知时，这些数值没有可比性。

ABB 已经根据间接法计算出效率值，且根据测量得出杂散损耗（附加损耗）。

Efficiency values are given according to IEC 60034-2-1 edition 2.0, 2014-06.

Please note that the values are not comparable without knowing the testing method.

ABB has calculated the efficiency values according to indirect method, stray load losses (additional losses) determined from measuring.

I_s / I_N = 启动电流
 T_l / T_N = 转子堵转转矩
 T_b / T_N = 最大转矩

I_s / I_N = Starting current
 T_l / T_N = Locked rotor torque
 T_b / T_N = Breakdown torque

三相全封闭鼠笼式电机的技术数据

Technical data for totally enclosed squirrel cage three phase motors

IP 55 – IC 411 – 绝缘等级 F, 温升等级 B

0.18-0.75kW, 符合 GB 25958-2010 的 3 级能效

0.75-355kW, 符合 IEC 60034-30-1; 2014 的 IE2 效率等级及 GB 18613-2012 的 3 级能效

IP 55 - IC 411 - Insulation class F, temperature rise class B

0.18-0.75kW, Grade 3 according to GB 25958-2010

0.75-355kW, IE2 efficiency class according to 60034-30-1; 2014 , Grade 3 according to GB 18613-2012

输出 Output	电机型号 Motor type	产品代码 Product code	转速 Speed	效率 / Efficiency IEC 60034-2-1; 2007			功率 因数 Power factor cos φ	电流 Current			转矩 / Torque			转动惯量 Moment of inertia J=1/4 GD ² kgm ²	重量 Weight kg	声压等级 Sound pressure level, L _{PA} dB
				满载 load 100%	3/4 负载 load 75%	1/2 负载 load 50%		I _N A	I _s / I _N	T _N Nm	T _I /T _N	T _B /T _N				
3000 r/min = 2 极 / 2 poles			400 V 50Hz			GENELEC- 设计 design										
0.37	M2BAX 71 MA	3GBA 071 310-●●CCN	2807	73.5	71.4	67.3	0.80	0.91	5.1	1.26	2.8	3.4	0.00033	9	56	
0.55	M2BAX 71 MB	3GBA 071 320-●●CCN	2820	75.5	73.9	70.2	0.79	1.33	5.5	1.86	3.6	3.2	0.00041	10	58	
0.75	M2BAX 80 MA	3GBA 081 310-●●CCN	2830	77.4	76.7	74.4	0.83	1.69	5.7	2.51	3.1	4.3	0.00067	13	63	
1.1	M2BAX 80 MB	3GBA 081 320-●●CCN	2849	79.6	79.7	77.7	0.84	2.37	5.8	3.67	3.2	4.1	0.00088	14	62	
1.5	M2BAX 90 SA	3GBA 091 110-●●CCN	2890	81.3	80.0	76.9	0.80	3.33	7.1	4.93	3.1	3.9	0.00208	20	66	
2.2	M2BAX 90 LA	3GBA 091 510-●●CCN	2897	83.2	82.9	81.2	0.85	4.49	7.7	7.25	3.1	3.8	0.00274	23	67	
3	M2BAX 100 LA	3GBA 101 510-●●CCN	2919	84.6	83.7	81.2	0.85	6.02	8.7	9.81	4.2	5.0	0.00475	32	74	
4	M2BAX 112 MA	3GBA 111 310-●●CCN	2916	85.8	85.3	83.1	0.87	7.73	9.1	13.1	4.1	4.7	0.00561	36	74	
5.5	M2BAX 132 SA	3GBA 131 110-●●CCN	2921	87.0	85.9	83.6	0.86	10.6	8.3	18.0	2.6	4.3	0.01170	54	74	
7.5	M2BAX 132 SB	3GBA 131 120-●●CCN	2916	88.1	87.5	85.8	0.85	14.5	8.7	24.6	3.1	4.5	0.01319	58	72	
11	M2BAX 160 MLA	3GBA 161 410-●●CCN	2931	89.4	89.4	88.4	0.86	20.7	6.6	35.9	2.5	3.5	0.041	102	72	
15	M2BAX 160 MLB	3GBA 161 420-●●CCN	2938	90.3	90.6	89.8	0.89	26.9	7.6	48.9	3.0	3.5	0.054	115	72	
18.5	M2BAX 160 MLC	3GBA 161 430-●●CCN	2939	90.9	91.0	90.3	0.88	33.4	7.9	60.1	3.1	3.8	0.060	123	73	
22	M2BAX 180 MLA	3GBA 181 410-●●CCN	2943	91.3	91.4	90.7	0.88	39.5	8.4	71.4	3.8	3.9	0.073	150	72	
30	M2BAX 200 MLA	3GBA 201 410-●●CCN	2957	92.0	91.5	90.1	0.85	55.4	8.6	97.1	4.0	4.2	0.110	198	81	
37	M2BAX 200 MLB	3GBA 201 420-●●CCN	2951	92.5	92.5	92.1	0.90	64.2	8.4	120	3.6	3.7	0.141	229	80	
45	M2BAX 225 SMA	3GBA 221 210-●●CCN	2962	92.9	92.8	92.1	0.87	80.4	8.8	145	3.8	3.8	0.226	273	82	
55	M2BAX 250 SMA	3GBA 251 210-●●CCN	2965	93.2	93.2	92.6	0.88	96.8	7.4	177	3.4	3.0	0.344	334	78	
75	M2BAX 280 SMD	3GBA 281 240-●●HCN	2971	93.8	94.0	93.9	0.88	130	8.2	241	3.6	3.6	0.6	527	78	
90	M2BAX 280 SME	3GBA 281 250-●●HCN	2974	94.1	94.3	94.2	0.90	151	8.0	289	4.0	3.5	0.7	576	76	
110	M2BAX 315 SMA	3GBA 311 210-●●CCN	2982	94.6	94.1	92.7	0.86	195	7.6	352	2.0	3.0	1.2	767	78	
132	M2BAX 315 SMB	3GBA 311 220-●●CCN	2982	94.9	94.6	93.4	0.88	228	7.4	422	2.2	3.0	1.4	827	78	
160	M2BAX 315 SMC	3GBA 311 230-●●CCN	2981	95.2	95.0	94.1	0.89	272	7.5	512	2.3	3.0	1.7	917	78	
200	M2BAX 315 MLA	3GBA 311 410-●●CCN	2980	95.3	95.2	94.4	0.90	336	7.7	640	2.6	3.0	2.1	1037	83	
250	M2BAX 355 SMA	3GBA 351 210-●●CCN	2983	95.4	95.2	94.3	0.89	424	6.8	800	1.5	2.8	2.7	1329	83	
315	M2BAX 355 SMB	3GBA 351 220-●●CCN	2980	95.4	95.4	94.7	0.89	535	7.2	1009	1.9	2.8	3.4	1469	83	
355 ¹⁾	M2BAX 355 SMC	3GBA 351 230-●●CCN	2983	95.5	95.5	94.9	0.88	609	7.4	1136	2.1	2.7	3.6	1539	83	

¹⁾ 温升等级 F ¹⁾ temperature rise class F

产品代码中的两个圆点表示可选的安装方式、电压及频率代码（见订购信息一页）。

The two bullets in the product code indicate choice of mounting arrangements, voltage and frequency code (see ordering information page).

根据 IEC 60034-2-1 edition 2.0, 2014-06 的要求, 给出效率值。

请注意, 在测试方法未知时, 这些数值没有可比性。

ABB 已经根据间接法计算出效率值, 且根据测量得出杂散损耗 (附加损耗)。

Efficiency values are given according to IEC 60034-2-1 edition 2.0, 2014-06.

Please note that the values are not comparable without knowing the testing method.

ABB has calculated the efficiency values according to indirect method, stray load losses (additional losses) determined from measuring.

I_s / I_N = 启动电流

T_I / T_N = 转子堵转转矩

T_b / T_N = 最大转矩

I_s / I_N = Starting current

T_I / T_N = Locked rotor torque

T_b / T_N = Breakdown torque

三相全封闭鼠笼式电机的技术数据

Technical data for totally enclosed squirrel cage three phase motors

IP 55 – IC 411 – 绝缘等级 F, 温升等级 B

0.18-0.75kW, 符合 GB 25958-2010 的 3 级能效

0.75-355kW, 符合 IEC 60034-30-1; 2014 的 IE2 效率等级及 GB 18613-2012 的 3 级能效

IP 55 - IC 411 - Insulation class F, temperature rise class B

0.18-0.75kW, Grade 3 according to GB 25958-2010

0.75-355kW, IE2 efficiency class according to 60034-30-1; 2014, Grade 3 according to GB 18613-2012

输出 Output	电机型号 Motor type	产品代码 Product code	转速 Speed	效率 / Efficiency IEC 60034-2-1; 2007			功率 因数 Power factor cos φ	电流 Current		转矩 / Torque			转动惯量 Moment of inertia J=1/4 GD ² kgm ²	重量 Weight kg	声压等级 Sound pressure level, L _{PA} dB
				满载 load 100%	3/4 负载 load 75%	1/2 负载 load 50%		I _N A	I _s /I _N	T _N Nm	T _l /T _N	T _b /T _N			
1500 r/min = 4 极 / 4 poles			380 V 50Hz			GENELEC- 设计 design									
0.25	M2BAX 71 MA	3GBA 072 310-••CCN	1404	67.0	64.1	58.6	0.77	0.74	4.2	1.68	1.9	2.5	0.00059	9	49
0.37	M2BAX 71 MB	3GBA 072 320-••CCN	1393	69.5	68.5	65.2	0.81	1.00	4.2	2.52	1.8	2.3	0.00076	10	46
0.55	M2BAX 80 MA	3GBA 082 310-••CCN	1402	73.5	72.8	70.1	0.80	1.42	4.8	3.70	2.1	2.6	0.00156	13	54
0.75	M2BAX 80 MB	3GBA 082 320-••CCN	1438	79.6	79.5	76.5	0.75	1.91	6.4	4.97	3.4	3.5	0.00247	17	53
1.1	M2BAX 90 SA	3GBA 092 110-••CCN	1440	81.4	80.4	77.3	0.77	2.67	6.3	7.35	3.5	3.8	0.00372	21	51
1.5	M2BAX 90 LA	3GBA 092 510-••CCN	1435	82.8	81.9	80.0	0.78	3.53	6.6	10.0	3.3	3.8	0.00462	23	55
2.2	M2BAX 100 LA	3GBA 102 510-••CCN	1437	84.3	84.1	82.9	0.82	4.84	6.7	14.5	2.9	3.4	0.00759	31	55
3	M2BAX 100 LB	3GBA 102 520-••CCN	1437	85.5	85.4	84.2	0.81	6.58	7.3	19.8	3.2	3.8	0.00939	35	58
4	M2BAX 112 MA	3GBA 112 310-••CCN	1433	86.6	87.0	86.1	0.83	8.46	7.1	26.5	3.6	3.9	0.01195	41	56
5.5	M2BAX 132 SA	3GBA 132 110-••CCN	1451	87.7	87.8	87.2	0.81	11.8	6.4	36.0	2.2	3.0	0.02570	57	66
7.5	M2BAX 132 MA	3GBA 132 310-••CCN	1453	88.7	89.0	88.6	0.81	15.9	6.8	49.1	2.3	3.2	0.03195	68	66
11	M2BAX 160 MLA	3GBA 162 410-••CCN	1461	89.8	90.2	90.1	0.82	22.7	7.0	71.5	2.9	2.9	0.078	110	67
15	M2BAX 160 MLB	3GBA 162 420-••CCN	1463	90.6	91.1	91	0.84	29.9	7.4	97.7	2.9	3.3	0.100	125	66
18.5	M2BAX 180 MLA	3GBA 182 410-••CCN	1467	91.2	91.5	91.2	0.83	37.1	7.9	121	3.3	3.7	0.120	155	65
22	M2BAX 180 MLB	3GBA 182 420-••CCN	1468	91.6	91.7	91.1	0.82	44.5	8.7	143	3.7	4.1	0.139	168	66
30	M2BAX 200 MLA	3GBA 202 410-••CCN	1471	92.3	92.8	92.9	0.84	58.8	6.5	194	2.7	2.8	0.236	222	68
37	M2BAX 225 SMA	3GBA 222 210-••CCN	1476	92.7	93	93	0.85	71.3	6.9	239	2.8	2.9	0.350	263	69
45	M2BAX 225 SMB	3GBA 222 220-••CCN	1478	93.1	93.4	93.1	0.84	87.4	7.5	291	3.1	3.1	0.416	290	69
55	M2BAX 250 SMA	3GBA 252 210-••CCN	1478	93.5	93.8	93.4	0.85	105	7.1	356	2.9	2.9	0.533	339	77
75	M2BAX 280 SMD	3GBA 282 240-••HCN	1476	94.0	94.6	94.4	0.85	142	7.8	485	2.8	3.1	0.9	520	70
90	M2BAX 280 SME	3GBA 282 250-••HCN	1476	94.2	94.8	94.6	0.87	167	7.8	582	2.9	3.1	1.1	583	70
110	M2BAX 315 SMA	3GBA 312 210-••CCN	1486	94.6	94.7	93.9	0.87	203	6.5	706	1.8	2.3	2.3	792	78
132	M2BAX 315 SMB	3GBA 312 220-••CCN	1486	94.9	95.0	94.5	0.87	242	6.4	847	2.0	2.4	2.6	847	78
160	M2BAX 315 SMC	3GBA 312 230-••CCN	1485	95.1	95.3	94.8	0.86	297	6.6	1028	2.1	2.6	2.9	887	78
200	M2BAX 315 MLA	3GBA 312 410-••CCN	1484	95.2	95.4	95.1	0.87	366	6.4	1286	2.1	2.5	3.5	1012	78
250	M2BAX 355 SMA	3GBA 352 210-••CCN	1487	95.1	95.2	94.5	0.86	464	6.0	1605	1.8	2.3	5.4	1419	82
315 ¹⁾	M2BAX 355 SMB	3GBA 352 220-••CCN	1487	95.4	95.5	95.0	0.86	583	6.7	2021	2.0	2.4	6.9	1589	82
355 ¹⁾	M2BAX 355 SMC	3GBA 352 230-••CCN	1485	95.4	95.7	95.3	0.87	649	6.1	2279	2.1	2.3	7.2	1669	84

¹⁾ 温升等级 F ¹⁾ temperature rise class F

产品代码中的两个圆点表示可选的安装方式、电压及频率代码（见订购信息一页）。

The two bullets in the product code indicate choice of mounting arrangements, voltage and frequency code (see ordering information page).

根据 IEC 60034-2-1 edition 2.0, 2014-06 的要求, 给出效率值。

请注意, 在测试方法未知时, 这些数值没有可比性。

ABB 已经根据间接法计算出效率值, 且根据测量得出杂散损耗 (附加损耗)。

Efficiency values are given according to IEC 60034-2-1 edition 2.0, 2014-06.

Please note that the values are not comparable without knowing the testing method.

ABB has calculated the efficiency values according to indirect method, stray load losses (additional losses) determined from measuring.

I_s / I_N = 启动电流

T_l / T_N = 转子堵转转矩

T_b / T_N = 最大转矩

I_s / I_N = Starting current

T_l / T_N = Locked rotor torque

T_b / T_N = Breakdown torque

三相全封闭鼠笼式电机的技术数据

Technical data for totally enclosed squirrel cage three phase motors

IP 55 – IC 411 – 绝缘等级 F，温升等级 B

0.18-0.75kW，符合 GB 25958-2010 的 3 级能效

0.75-355kW，符合 IEC 60034-30-1; 2014 的 IE2 效率等级及 GB 18613-2012 的 3 级能效

IP 55 - IC 411 - Insulation class F, temperature rise class B

0.18-0.75kW, Grade 3 according to GB 25958-2010

0.75-355kW, IE2 efficiency class according to 60034-30-1; 2014 , Grade 3 according to GB 18613-2012

输出 Output	电机型号 Motor type	产品代码 Product code	转速 Speed	效率 / Efficiency IEC 60034-2-1; 2007			功率 因数 Power factor cos φ	电流 Current		转矩 / Torque			转动惯量 Moment of inertia J=1/4 GD ² kgm ²	重量 Weight kg	声压等级 Sound pressure level, L _{PA} dB
				满载 load 100%	3/4 负载 load 75%	1/2 负载 load 50%		I _N A	I _s / I _N	T _N Nm	T _i /T _N	T _b /T _N			
1500 r/min = 4 极 / 4 poles			400 V 50Hz				GENELEC- 设计 design								
0.25	M2BAX 71 MA	3GBA 072 310-••CCN	1415	67.0	63.1	56.6	0.73	0.74	4.4	1.68	2.1	2.8	0.00059	9	49
0.37	M2BAX 71 MB	3GBA 072 320-••CCN	1407	69.5	67.2	62.2	0.77	1.00	4.4	2.50	2.0	2.6	0.00076	10	46
0.55	M2BAX 80 MA	3GBA 082 310-••CCN	1413	73.5	72.0	67.8	0.76	1.42	5.1	3.70	2.4	2.9	0.00156	13	54
0.75	M2BAX 80 MB	3GBA 082 320-••CCN	1462	79.6	77.1	73.2	0.71	1.92	6.7	4.97	3.8	3.9	0.00247	17	53
1.1	M2BAX 90 SA	3GBA 092 110-••CCN	1447	81.4	79.5	75.7	0.73	2.67	6.6	7.35	3.9	4.3	0.00372	21	51
1.5	M2BAX 90 LA	3GBA 092 510-••CCN	1441	82.8	81.6	78.4	0.74	3.53	6.9	10.0	3.7	4.2	0.00462	23	55
2.2	M2BAX 100 LA	3GBA 102 510-••CCN	1445	84.3	83.4	81.2	0.78	4.83	7.1	14.5	3.2	3.8	0.00759	31	55
3	M2BAX 100 LB	3GBA 102 520-••CCN	1443	85.5	85.0	82.9	0.77	6.58	7.7	19.8	3.6	4.2	0.00939	35	58
4	M2BAX 112 MA	3GBA 112 310-••CCN	1442	86.6	86.2	84.6	0.79	8.44	7.5	26.5	4.0	4.3	0.01195	41	56
5.5	M2BAX 132 SA	3GBA 132 110-••CCN	1457	87.7	87.5	86.2	0.78	11.6	6.9	36.0	2.5	3.4	0.02570	57	66
7.5	M2BAX 132 MA	3GBA 132 310-••CCN	1457	88.7	88.6	87.5	0.78	15.6	7.2	49.1	2.6	3.6	0.03195	68	66
11	M2BAX 160 MLA	3GBA 162 410-••CCN	1466	89.8	89.9	89.2	0.79	22.4	7.0	71.5	3.2	3.2	0.078	110	67
15	M2BAX 160 MLB	3GBA 162 420-••CCN	1468	90.6	91.1	90.5	0.82	29.1	8.0	97.7	3.2	3.7	0.100	125	66
18.5	M2BAX 180 MLA	3GBA 182 410-••CCN	1470	91.2	91.5	90.6	0.80	36.6	8.5	120	3.7	4.2	0.120	155	65
22	M2BAX 180 MLB	3GBA 182 420-••CCN	1472	91.6	91.3	90.2	0.78	44.4	9.2	143	4.1	4.6	0.139	168	66
30	M2BAX 200 MLA	3GBA 202 410-••CCN	1476	92.3	92.4	92.0	0.81	57.9	6.8	194	3.0	3.2	0.236	222	68
37	M2BAX 225 SMA	3GBA 222 210-••CCN	1479	92.7	92.7	92.2	0.82	70.3	7.4	239	3.1	3.3	0.350	263	69
45	M2BAX 225 SMB	3GBA 222 220-••CCN	1481	93.1	93.0	92.3	0.83	84.1	7.9	290	3.5	3.5	0.416	290	69
55	M2BAX 250 SMA	3GBA 252 210-••CCN	1480	93.5	93.4	92.7	0.83	102	7.6	355	3.3	3.3	0.533	339	77
75	M2BAX 280 SMD	3GBA 282 240-••HCN	1480	94.0	94.1	93.8	0.83	138	8.4	484	3.3	3.5	0.9	520	70
90	M2BAX 280 SME	3GBA 282 250-••HCN	1480	94.2	94.3	94.0	0.86	160	7.8	581	3.3	3.4	1.1	583	70
110	M2BAX 315 SMA	3GBA 312 210-••CCN	1487	94.7	94.6	93.8	0.86	194	7.2	706	2.0	2.5	2.3	792	78
132	M2BAX 315 SMB	3GBA 312 220-••CCN	1487	95.0	95.0	94.3	0.86	233	7.1	847	2.3	2.7	2.6	847	78
160	M2BAX 315 SMC	3GBA 312 230-••CCN	1487	95.2	95.3	94.6	0.85	285	7.2	1027	2.4	2.9	2.9	887	78
200	M2BAX 315 MLA	3GBA 312 410-••CCN	1486	95.3	95.4	94.9	0.86	352	7.0	1285	2.3	2.8	3.5	1012	78
250	M2BAX 355 SMA	3GBA 352 210-••CCN	1488	95.2	95.2	94.4	0.85	445	6.7	1604	2.0	2.6	5.4	1419	82
315 ¹⁾	M2BAX 355 SMB	3GBA 352 220-••CCN	1488	95.5	95.5	94.8	0.85	560	7.3	2021	2.2	2.7	6.9	1589	82
355 ¹⁾	M2BAX 355 SMC	3GBA 352 230-••CCN	1487	95.5	95.7	95.2	0.86	623	6.8	2279	2.4	2.7	7.2	1669	82

¹⁾ 温升等级 F ¹⁾ temperature rise class F

产品代码中的两个圆点表示可选的安装方式、电压及频率代码（见订购信息一页）。

The two bullets in the product code indicate choice of mounting arrangements, voltage and frequency code (see ordering information page).

根据 IEC 60034-2-1 edition 2.0, 2014-06 的要求，给出效率值。

请注意，在测试方法未知时，这些数值没有可比性。

ABB 已经根据间接法计算出效率值，且根据测量得出杂散损耗（附加损耗）。

Efficiency values are given according to IEC 60034-2-1 edition 2.0, 2014-06.

Please note that the values are not comparable without knowing the testing method.

ABB has calculated the efficiency values according to indirect method, stray load losses (additional losses) determined from measuring.

I_s / I_N = 启动电流

T_i / T_N = 转子堵转转矩

T_b / T_N = 最大转矩

I_s / I_N = Starting current

T_i / T_N = Locked rotor torque

T_b / T_N = Breakdown torque

三相全封闭鼠笼式电机的技术数据

Technical data for totally enclosed squirrel cage three phase motors

IP 55 – IC 411 – 绝缘等级 F, 温升等级 B

0.18-0.75kW, 符合 GB 25958-2010 的 3 级能效

0.75-355kW, 符合 IEC 60034-30-1; 2014 的 IE2 效率等级及 GB 18613-2012 的 3 级能效

IP 55 - IC 411 - Insulation class F, temperature rise class B

0.18-0.75kW, Grade 3 according to GB 25958-2010

0.75-355kW, IE2 efficiency class according to 60034-30-1; 2014, Grade 3 according to GB 18613-2012

输出 Output	电机型号 Motor type	产品代码 Product code	转速 Speed	效率 / Efficiency IEC 60034-2-1; 2007			功率 因数 Power factor cos φ	电流 Current			转矩 / Torque			转动惯量 Moment of inertia J=1/4 GD ² kgm ²	重量 Weight kg	声压等级 Sound pressure level, L _{PA} dB
				满载 load 100%	3/4 负载 load 75%	1/2 负载 load 50%		I _N A	I _s / I _N	T _N Nm	T _l /T _N	T _b /T _N				
kW			r/min	380 V 50Hz			CENELEC- 设计 design									
1000 r/min = 6 极 / 6 poles																
0.18	M2BAX 71 MA	3GBA 073 310-●●CCN	890	59.0	56.5	50.9	0.77	0.60	3.1	1.87	1.8	2.1	0.00082	9	40	
0.25	M2BAX 71 MB	3GBA 073 320-●●CCN	896	63.0	61.4	56.7	0.76	0.79	3.5	2.64	2.1	2.5	0.00105	10	47	
0.37	M2BAX 80 MA	3GBA 083 310-●●CCN	906	68.0	67.4	63.4	0.80	1.03	4.0	3.84	2.2	2.5	0.00173	13	49	
0.55	M2BAX 80 MB	3GBA 083 320-●●CCN	908	71.0	70.6	67.5	0.77	1.53	4.2	5.74	2.6	2.6	0.00234	14	47	
0.75	M2BAX 90 SA	3GBA 093 110-●●CCN	945	75.9	74	69.6	0.66	2.27	4.8	7.58	3.0	3.3	0.00438	21	50	
1.1	M2BAX 90 LA	3GBA 093 510-●●CCN	926	78.1	77.4	74.8	0.71	3.01	4.4	11.1	2.7	3.0	0.00507	24	48	
1.5	M2BAX 100 LA	3GBA 103 510-●●CCN	946	79.8	79.3	77.2	0.71	4.02	5.0	15.0	2.3	2.8	0.00795	31	56	
2.2	M2BAX 112 MA	3GBA 113 310-●●CCN	950	81.8	81.1	79.1	0.72	5.68	5.3	21.9	2.6	3.2	0.01157	40	54	
3	M2BAX 132 SA	3GBA 133 110-●●CCN	962	83.3	83.2	82.1	0.69	7.93	5.3	29.5	1.8	2.7	0.02509	55	60	
4	M2BAX 132 MA	3GBA 133 310-●●CCN	959	84.6	84.9	84.1	0.74	9.71	6.0	40.0	2.4	3.0	0.02935	63	58	
5.5	M2BAX 132 MB	3GBA 133 320-●●CCN	959	86.0	86.4	86.0	0.71	13.7	5.5	54.2	2.0	2.6	0.03972	77	62	
7.5	M2BAX 160 MLA	3GBA 163 410-●●CCN	977	87.2	87.3	86.5	0.74	17.7	6.9	73.1	2.0	3.2	0.081	113	61	
11	M2BAX 160 MLB	3GBA 163 420-●●CCN	977	88.7	88.7	87.9	0.73	25.8	7.6	108	2.2	3.7	0.102	133	62	
15	M2BAX 180 MLA	3GBA 183 410-●●CCN	968	89.7	90.3	90.6	0.80	31.8	7.4	147	2.1	3.5	0.136	168	62	
18.5	M2BAX 200 MLA	3GBA 203 410-●●CCN	975	90.4	90.8	90.7	0.80	38.9	5.6	181	1.8	2.6	0.204	205	61	
22	M2BAX 200 MLB	3GBA 203 420-●●CCN	974	90.9	91.3	91.3	0.80	46.0	5.7	216	1.6	2.6	0.227	219	62	
30	M2BAX 225 SMA	3GBA 223 210-●●CCN	986	91.7	91.9	91.5	0.82	60.6	6.7	290	2.4	2.9	0.579	282	64	
37	M2BAX 250 SMA	3GBA 253 210-●●CCN	985	92.2	92.7	92.6	0.84	72.6	6.4	359	2.3	2.6	0.783	336	66	
45	M2BAX 280 SMD	3GBA 283 240-●●HCN	989	92.7	93.1	92.9	0.82	90.1	6.5	434	2.4	2.8	1.3	498	62	
55	M2BAX 280 SME	3GBA 283 250-●●HCN	988	93.1	93.5	93.3	0.83	108	6.3	531	2.4	2.7	1.5	523	66	
75	M2BAX 315 SMA	3GBA 313 210-●●CCN	991	94.0	94.1	93.4	0.83	146	6.5	722	1.9	2.4	3.2	722	75	
90	M2BAX 315 SMB	3GBA 313 220-●●CCN	991	94.2	94.4	93.9	0.84	172	6.6	866	1.9	2.4	4.1	817	75	
110	M2BAX 315 SMC	3GBA 313 230-●●CCN	990	94.6	94.9	94.4	0.84	210	6.4	1058	2.0	2.4	4.9	887	75	
132	M2BAX 315 MLA	3GBA 313 410-●●CCN	991	94.8	95.1	94.6	0.84	251	6.6	1270	2.2	2.4	5.8	997	75	
160	M2BAX 355 SMA	3GBA 353 210-●●CCN	991	94.8	95.0	94.6	0.84	305	5.7	1541	1.9	2.1	7.3	1309	77	
200	M2BAX 355 SMB	3GBA 353 220-●●CCN	991	95.1	95.4	95.1	0.85	375	5.9	1927	1.9	2.1	9.7	1459	77	
250 ¹⁾	M2BAX 355 SMC	3GBA 353 230-●●CCN	990	95.1	95.5	95.3	0.85	469	6.1	2409	2.1	2.1	11.3	1609	77	

¹⁾ 温升等级 F ¹⁾ temperature rise class F

产品代码中的两个圆点表示可选的安装方式、电压及频率代码（见订购信息一页）。

The two bullets in the product code indicate choice of mounting arrangements, voltage and frequency code (see ordering information page).

根据 IEC 60034-2-1 edition 2.0, 2014-06 的要求, 给出效率值。

请注意, 在测试方法未知时, 这些数值没有可比性。

ABB 已经根据间接法计算出效率值, 且根据测量得出杂散损耗 (附加损耗)。

Efficiency values are given according to IEC 60034-2-1 edition 2.0, 2014-06.

Please note that the values are not comparable without knowing the testing method.

ABB has calculated the efficiency values according to indirect method, stray load losses (additional losses) determined from measuring.

I_s / I_N = 启动电流

T_l / T_N = 转子堵转转矩

T_b / T_N = 最大转矩

I_s / I_N = Starting current

T_l / T_N = Locked rotor torque

T_b / T_N = Breakdown torque

三相全封闭鼠笼式电机的技术数据

Technical data for totally enclosed squirrel cage three phase motors

IP 55 – IC 411 – 绝缘等级 F, 温升等级 B

0.18-0.75kW, 符合 GB 25958-2010 的 3 级能效

0.75-355kW, 符合 IEC 60034-30-1; 2014 的 IE2 效率等级及 GB 18613-2012 的 3 级能效

IP 55 - IC 411 - Insulation class F, temperature rise class B

0.18-0.75kW, Grade 3 according to GB 25958-2010

0.75-355kW, IE2 efficiency class according to 60034-30-1; 2014 , Grade 3 according to GB 18613-2012

输出 Output	电机型号 Motor type	产品代码 Product code	转速 Speed	效率 / Efficiency IEC 60034-2-1; 2007			功率 因数 Power factor cos φ	电流 Current		转矩 / Torque			转动惯量 Moment of inertia J=1/4 GD ² kgm ²	重量 Weight kg	声压等级 Sound pressure level, L _{PA} dB
				满载 load 100%	3/4 负载 load 75%	1/2 负载 load 50%		I _N A	I _s / I _N	T _N Nm	T _i /T _N	T _b /T _N			
1000 r/min = 6 极 / 6 poles			400 V 50Hz					CENELEC- 设计 design							
0.18	M2BAX 71 MA	3GBA 073 310-●●CCN	910	59.0	54.7	47.5	0.72	0.61	3.3	1.87	2.0	2.4	0.00082	9	40
0.25	M2BAX 71 MB	3GBA 073 320-●●CCN	913	63.0	59.9	53.8	0.71	0.81	3.6	2.64	2.4	2.8	0.00105	10	47
0.37	M2BAX 80 MA	3GBA 083 310-●●CCN	919	68.0	65.9	60.7	0.74	1.06	4.2	3.84	2.5	2.7	0.00173	13	49
0.55	M2BAX 80 MB	3GBA 083 320-●●CCN	921	71.0	69.6	64.9	0.73	1.53	4.4	5.74	2.9	3.0	0.00234	14	47
0.75	M2BAX 90 SA	3GBA 093 110-●●CCN	949	75.9	73.0	67.7	0.62	2.30	5.1	7.60	3.3	3.7	0.00438	21	50
1.1	M2BAX 90 LA	3GBA 093 510-●●CCN	936	78.1	76.2	72.8	0.67	3.03	4.6	11.1	3.0	3.3	0.00507	24	48
1.5	M2BAX 100 LA	3GBA 103 510-●●CCN	953	79.8	78.4	75.1	0.67	4.05	5.2	15.0	2.6	3.1	0.00795	31	56
2.2	M2BAX 112 MA	3GBA 113 310-●●CCN	956	81.8	80.4	77.4	0.68	5.71	5.5	21.9	2.9	3.5	0.01157	40	54
3	M2BAX 132 SA	3GBA 133 110-●●CCN	967	83.3	82.5	80.2	0.65	8.00	5.5	29.5	2.0	3.0	0.02509	55	60
4	M2BAX 132 MA	3GBA 133 310-●●CCN	965	84.6	84.2	82.4	0.70	9.75	5.7	40.0	2.6	3.3	0.02832	63	62
5.5	M2BAX 132 MB	3GBA 133 320-●●CCN	964	86.0	85.9	84.7	0.68	13.6	5.8	54.2	2.2	2.9	0.03972	77	62
7.5	M2BAX 160 MLA	3GBA 163 410-●●CCN	974	87.2	87.5	87.0	0.76	16.3	6.6	73.7	2.0	3.2	0.081	113	61
11	M2BAX 160 MLB	3GBA 163 420-●●CCN	971	88.7	89.4	89.8	0.79	22.7	6.6	108	1.6	2.8	0.102	133	62
15	M2BAX 180 MLA	3GBA 183 410-●●CCN	971	89.7	90.0	89.6	0.77	31.3	7.4	147	2.4	3.9	0.136	168	62
18.5	M2BAX 200 MLA	3GBA 203 410-●●CCN	978	90.4	90.7	90.0	0.77	38.4	6.1	181	2.0	2.9	0.204	205	61
22	M2BAX 200 MLB	3GBA 203 420-●●CCN	978	90.9	91.1	90.5	0.78	44.8	6.2	215	1.8	2.9	0.227	219	62
30	M2BAX 225 SMA	3GBA 223 210-●●CCN	987	91.7	91.5	90.5	0.79	59.8	7.0	290	2.7	3.2	0.579	282	64
37	M2BAX 250 SMA	3GBA 253 210-●●CCN	986	92.2	92.5	91.9	0.81	71.5	6.9	359	2.6	2.9	0.783	336	66
45	M2BAX 280 SMD	3GBA 283 240-●●HCN	990	92.7	92.8	92.4	0.80	88.2	7.1	434	2.7	3.1	1.3	498	62
55	M2BAX 280 SME	3GBA 283 250-●●HCN	989	93.1	93.2	92.8	0.81	105	6.9	531	2.7	2.9	1.5	523	66
75	M2BAX 315 SMA	3GBA 313 210-●●CCN	992	94.0	94.0	93.0	0.81	142	7.0	721	2.1	2.7	3.2	722	75
90	M2BAX 315 SMB	3GBA 313 220-●●CCN	992	94.3	94.4	93.6	0.83	165	7.2	866	2.1	2.7	4.1	817	75
110	M2BAX 315 SMC	3GBA 313 230-●●CCN	992	94.7	94.8	94.2	0.83	201	7.0	1058	2.2	2.7	4.9	887	75
132	M2BAX 315 MLA	3GBA 313 410-●●CCN	992	94.9	95.0	94.4	0.83	241	7.2	1270	2.4	2.7	5.8	997	75
160	M2BAX 355 SMA	3GBA 353 210-●●CCN	992	94.9	95.0	94.4	0.83	293	6.2	1540	2.1	2.3	7.3	1309	77
200	M2BAX 355 SMB	3GBA 353 220-●●CCN	992	95.2	95.4	94.9	0.84	360	6.5	1925	2.1	2.3	9.7	1459	77
250 ¹⁾	M2BAX 355 SMC	3GBA 353 230-●●CCN	991	95.3	95.5	95.2	0.84	450	6.7	2409	2.3	2.3	11.3	1609	77

¹⁾ 温升等级 F ¹⁾ temperature rise class F

产品代码中的两个圆点表示可选的安装方式、电压及频率代码（见订购信息一页）。

The two bullets in the product code indicate choice of mounting arrangements, voltage and frequency code (see ordering information page).

根据 IEC 60034-2-1 edition 2.0, 2014-06 的要求，给出效率值。

请注意，在测试方法未知时，这些数值没有可比性。

ABB 已经根据间接法计算出效率值，且根据测量得出杂散损耗（附加损耗）。

Efficiency values are given according to IEC 60034-2-1 edition 2.0, 2014-06.

Please note that the values are not comparable without knowing the testing method.

ABB has calculated the efficiency values according to indirect method, stray load losses (additional losses) determined from measuring.

I_s / I_N = 启动电流

T_i / T_N = 转子堵转转矩

T_b / T_N = 最大转矩

I_s / I_N = Starting current

T_i / T_N = Locked rotor torque

T_b / T_N = Breakdown torque

三相全封闭鼠笼式电机的技术数据

Technical data for totally enclosed squirrel cage three phase motors

IP 55 – IC 411 – 绝缘等级 F，温升等级 B

符合 IEC 60034-30-1; 2014 的 IE3 效率等级及 GB 18613-2012 的 2 级能效

IP 55 - IC 411 - Insulation class F, temperature rise class B

IE3 efficiency class according to IEC 60034-30-1; 2014 , Grade 2 according to GB 18613-2012

输出 Output	电机型号 Motor type	产品代码 Product code	转速 Speed	效率 / Efficiency IEC 60034-2-1; 2007			功率 因数 Power factor	电流 Current			转矩 / Torque		转动惯量 Moment of inertia	重量 Weight	声压等级 Sound pressure level, L _{PA} dB
				满载 load 100%	3/4 负载 load 75%	1/2 负载 load 50%		cos φ	I _N A	I _s /I _N	T _N Nm	T _l /T _N			
kW			r/min					CENELEC- 设计 design					J=1/4 GD ² kgm ²	kg	
3000 r/min = 2 极 / 2 poles			380 V 50Hz												
0.37	M2BAX 71 MC	3GBA 071 330-●●DCN	2791	76.5	76.9	75.7	0.83	0.88	6.1	1.26	2.4	2.9	0.00035	9	50
0.55	M2BAX 71 MB	3GBA 071 320-●●DCN	2779	78.4	79.2	78.6	0.84	1.29	5.7	1.88	2.4	2.8	0.0004	10	49
0.75	M2BAX 80 MC	3GBA 081 330-●●DCN	2875	80.7	81.6	80.3	0.84	1.68	7.0	2.53	2.7	3.3	0.00081	15	58
1.1	M2BAX 80 MD	3GBA 081 340-●●DCN	2839	82.7	83.7	83.8	0.86	2.37	7.1	3.70	2.9	3.2	0.00102	17	60
1.5	M2BAX 90 SB	3GBA 091 120-●●DCN	2901	84.2	85.0	84.0	0.86	3.12	7.6	4.96	2.6	3.5	0.00234	22	54
2.2	M2BAX 90 SLA	3GBA 091 010-●●DCN	2893	85.9	86.3	85.7	0.85	4.58	7.9	7.28	2.9	3.5	0.00300	25	66
3	M2BAX 100 LKA	3GBA 101 810-●●DCN	2893	87.1	88.4	88.7	0.92	5.70	7.9	9.84	2.7	3.4	0.00691	47	60
4	M2BAX 112 MB	3GBA 111 320-●●DCN	2892	88.1	89.4	90.0	0.91	7.59	7.9	13.2	2.5	3.3	0.00711	46	64
5.5	M2BAX 132 SMA	3GBA 131 210-●●DCN	2926	89.2	90.0	89.7	0.84	11.0	7.7	18.0	2.2	3.7	0.0136	66	65
7.5	M2BAX 132 SMB	3GBA 131 220-●●DCN	2912	90.1	91.2	91.4	0.86	14.6	7.8	24.6	2.3	3.6	0.0166	76	65
11	M2BAX 160 MLA	3GBA 161 410-●●FCN	2933	91.2	92.0	92.1	0.92	20.1	6.5	35.7	2.3	3.2	0.057	128	69
15	M2BAX 160 MLB	3GBA 161 420-●●FCN	2939	91.9	92.5	92.4	0.90	27.5	7.9	48.6	2.8	3.8	0.063	131	69
18.5	M2BAX 160 MLC	3GBA 161 430-●●FCN	2939	92.4	93.2	93.2	0.91	33.5	7.7	59.9	3.0	3.5	0.076	152	73
22	M2BAX 180 MLA	3GBA 181 410-●●FCN	2934	92.7	93.2	93.1	0.89	40.6	7.9	71.6	3.1	3.7	0.073	151	70
30	M2BAX 200 MLA	3GBA 201 410-●●FCN	2955	93.3	93.5	92.9	0.91	54.1	8.2	96.9	3.3	3.7	0.144	144	80
37	M2BAX 200 MLB	3GBA 201 420-●●FCN	2943	93.7	94.0	93.7	0.90	66.6	8.5	119	3.7	3.7	0.160	212	78
45	M2BAX 225 SMA	3GBA 221 210-●●FCN	2960	94.0	94.2	93.7	0.87	83.7	8.4	145	3.4	3.7	0.223	276	80
55	M2BAX 250 SMA	3GBA 251 210-●●FCN	2958	94.3	93.5	93.4	0.89	99.6	7.4	177	3.1	2.7	0.344	334	78
75	M2BAX 280 SMB	3GBA 281 220-●●MCN	2974	94.7	94.6	93.8	0.88	137	6.3	241	2.0	2.7	0.9	596	74
90	M2BAX 280 SMC	3GBA 281 230-●●MCN	2972	95.0	95.1	94.4	0.89	162	5.8	289	1.9	2.5	1.0	618	74
110	M2BAX 315 SMB	3GBA 311 220-●●MCN	2980	95.2	95.0	94.1	0.88	199	6.4	352	1.6	2.4	1.3	801	78
132	M2BAX 315 SMC	3GBA 311 230-●●MCN	2979	95.4	95.4	94.6	0.89	236	6.2	422	1.8	2.5	1.5	852	78
160	M2BAX 315 SMD	3GBA 311 240-●●MCN	2980	95.6	95.6	95.0	0.88	289	6.7	512	2.0	2.5	1.7	909	78
200	M2BAX 315 MLA	3GBA 311 410-●●MCN	2980	95.8	96.0	95.7	0.89	356	6.8	641	2.1	2.8	2.1	1051	81
250	M2BAX 355 SMA	3GBA 351 210-●●MCN	2981	95.8	95.6	94.6	0.90	441	7.0	800	1.9	3.0	3.0	1412	83
315	M2BAX 355 SMB	3GBA 351 220-●●MCN	2977	95.8	95.8	95.1	0.89	561	6.3	1009	1.9	2.7	3.4	1495	83
355	M2BAX 355 SMC	3GBA 351 230-●●MCN	2981	95.8	95.8	95.2	0.89	633	6.5	1136	2.0	2.7	3.6	1565	83

产品代码中的两个圆点表示可选的安装方式、电压及频率代码（见订购信息一页）。

The two bullets in the product code indicate choice of mounting arrangements, voltage and frequency code (see ordering information page).

根据 IEC 60034-2-1 edition 2.0, 2014-06 的要求，给出效率值。

请注意，在测试方法未知时，这些数值没有可比性。

ABB 已经根据间接法计算出效率值，且根据测量得出杂散损耗（附加损耗）。

Efficiency values are given according to IEC 60034-2-1 edition 2.0, 2014-06.

Please note that the values are not comparable without knowing the testing method.

ABB has calculated the efficiency values according to indirect method, stray load losses (additional losses) determined from measuring.

I_s / I_N = 启动电流

T_l / T_N = 转子堵转转矩

T_b / T_N = 最大转矩

I_s / I_N = Starting current

T_l / T_N = Locked rotor torque

T_b / T_N = Breakdown torque

三相全封闭鼠笼式电机的技术数据

Technical data for totally enclosed squirrel cage three phase motors

IP 55 – IC 411 – 绝缘等级 F, 温升等级 B

符合 IEC 60034-30-1; 2014 的 IE3 效率等级及 GB 18613-2012 的 2 级能效

IP 55 - IC 411 - Insulation class F, temperature rise class B

IE3 efficiency class according to IEC 60034-30-1; 2014 , Grade 2 according to GB 18613-2012

输出 Output	电机型号 Motor type	产品代码 Product code	转速 Speed	效率 / Efficiency IEC 60034-2-1; 2007			功率 因数 Power factor cos φ	电流 Current		转矩 / Torque			转动惯量 Moment of inertia J=1/4 GD ² kgm ²	重量 Weight kg	声压等级 Sound pressure level, L _{PA} dB
				满载 load 100%	3/4 负载 load 75%	1/2 负载 load 50%		I _N A	I _s /I _N	T _N Nm	T _l /T _N	T _b /T _N			
3000 r/min = 2 极 / 2 poles			400 V	CENELEC- 设计 design											
0.37	M2BAX 71 MC	3GBA 071 330-••DCN	2819	76.5	76	73.4	0.80	0.86	6.6	1.26	2.7	3.2	0.00035	9	50
0.55	M2BAX 71 MB	3GBA 071 320-••DCN	2816	78.4	78.1	75.9	0.80	1.27	6.1	1.88	2.7	3.2	0.0004	10	49
0.75	M2BAX 80 MC	3GBA 081 330-••DCN	2891	80.7	81.0	78.9	0.80	1.66	7.5	2.49	2.9	3.7	0.00081	15	58
1.1	M2BAX 80 MD	3GBA 081 340-••DCN	2860	82.7	83.3	82.6	0.84	2.29	7.6	3.70	3.2	3.6	0.00102	17	60
1.5	M2BAX 90 SB	3GBA 091 120-••DCN	2912	84.2	84.0	82.5	0.83	3.04	8.0	4.96	2.8	3.9	0.00234	22	54
2.2	M2BAX 90 SLA	3GBA 091 010-••DCN	2908	85.9	85.6	83.9	0.81	4.54	8.2	7.26	3.2	3.9	0.00300	25	67
3	M2BAX 100 LKA	3GBA 101 810-••DCN	2910	87.1	88.0	88.0	0.91	5.38	8.3	9.84	3.0	3.8	0.00691	47	60
4	M2BAX 112 MB	3GBA 111 320-••DCN	2904	88.1	89.0	89.2	0.90	7.23	8.5	13.2	2.8	3.7	0.00711	46	64
5.5	M2BAX 132 SMA	3GBA 131 210-••DCN	2934	89.2	89.8	89.0	0.82	10.6	8.3	17.9	2.4	4.1	0.0136	66	65
7.5	M2BAX 132 SMB	3GBA 131 220-••DCN	2921	90.1	91.0	90.9	0.84	14.0	8.2	24.5	2.6	4.0	0.0166	76	65
11	M2BAX 160 MLA	3GBA 161 410-••FCN	2943	91.2	92.0	91.6	0.91	19.1	7.2	35.6	2.6	3.6	0.057	128	69
15	M2BAX 160 MLB	3GBA 161 420-••FCN	2947	91.9	92.2	91.8	0.88	26.5	7.8	48.5	3.2	4.2	0.063	131	69
18.5	M2BAX 160 MLC	3GBA 161 430-••FCN	2949	92.4	93.0	92.6	0.90	32.0	8.2	59.8	3.3	3.9	0.076	152	73
22	M2BAX 180 MLA	3GBA 181 410-••FCN	2941	92.7	93.0	92.7	0.84	41.1	8.1	71.4	3.4	4.1	0.073	151	70
30	M2BAX 200 MLA	3GBA 201 410-••FCN	2961	93.3	93.3	92.6	0.89	52.0	9.0	96.9	3.7	4.1	0.144	144	80
37	M2BAX 200 MLB	3GBA 201 420-••FCN	2951	93.7	93.9	93.3	0.89	63.9	9.5	119	4.2	4.1	0.160	212	78
45	M2BAX 225 SMA	3GBA 221 210-••FCN	2962	94.0	94.0	93.3	0.85	81.3	8.4	145	3.8	4.1	0.223	276	80
55	M2BAX 250 SMA	3GBA 251 210-••FCN	2965	94.3	93.2	92.6	0.88	96.8	7.4	177	3.4	3.0	0.344	334	78
75	M2BAX 280 SMB	3GBA 281 220-••MCN	2978	94.7	94.6	93.6	0.88	130	7.0	240	2.3	3.0	0.9	596	74
90	M2BAX 280 SMC	3GBA 281 230-••MCN	2975	95.0	95.0	94.2	0.88	156	6.4	289	2.1	2.8	1.0	618	74
110	M2BAX 315 SMB	3GBA 311 220-••MCN	2982	95.2	94.9	93.9	0.87	192	7.0	352	1.8	2.7	1.3	801	78
132	M2BAX 315 SMC	3GBA 311 230-••MCN	2982	95.4	95.4	94.6	0.87	229	6.8	422	2.0	2.8	1.5	852	78
160	M2BAX 315 SMD	3GBA 311 240-••MCN	2983	95.6	95.6	94.9	0.87	275	7.4	512	2.2	2.8	1.7	909	78
200	M2BAX 315 MLA	3GBA 311 410-••MCN	2983	95.8	96.0	95.5	0.88	342	7.5	640	2.3	3.1	2.1	1051	81
250	M2BAX 355 SMA	3GBA 351 210-••MCN	2985	95.8	95.6	94.6	0.89	423	7.7	800	2.1	3.3	3.0	1412	83
315	M2BAX 355 SMB	3GBA 351 220-••MCN	2980	95.8	95.7	95.0	0.89	529	7.0	1009	2.1	3.0	3.4	1495	83
355	M2BAX 355 SMC	3GBA 351 230-••MCN	2984	95.8	95.8	95.0	0.88	605	7.2	1136	2.2	3.0	3.6	1565	83

产品代码中的两个圆点表示可选的安装方式、电压及频率代码（见订购信息一页）。

The two bullets in the product code indicate choice of mounting arrangements, voltage and frequency code (see ordering information page).

根据 IEC 60034-2-1 edition 2.0, 2014-06 的要求，给出效率值。

请注意，在测试方法未知时，这些数值没有可比性。

ABB 已经根据间接法计算出效率值，且根据测量得出杂散损耗（附加损耗）。

Efficiency values are given according to IEC 60034-2-1 edition 2.0, 2014-06.

Please note that the values are not comparable without knowing the testing method.

ABB has calculated the efficiency values according to indirect method, stray load losses (additional losses) determined from measuring.

I_s / I_N = 启动电流

T_l / T_N = 转子堵转转矩

T_b / T_N = 最大转矩

I_s / I_N = Starting current

T_l / T_N = Locked rotor torque

T_b / T_N = Breakdown torque

三相全封闭鼠笼式电机的技术数据

Technical data for totally enclosed squirrel cage three phase motors

IP 55 – IC 411 – 绝缘等级 F, 温升等级 B

符合 IEC 60034-30-1; 2014 的 IE3 效率等级及 GB 18613-2012 的 2 级能效

IP 55 - IC 411 - Insulation class F, temperature rise class B

IE3 efficiency class according to IEC 60034-30-1; 2014 , Grade 2 according to GB 18613-2012

输出 Output	电机型号 Motor type	产品代码 Product code	转速 Speed	效率 / Efficiency IEC 60034-2-1; 2007			功率 因数 Power factor cos φ	电流 Current		转矩 / Torque			转动惯量 Moment of inertia J=1/4 GD ² kgm ²	重量 Weight kg	声压等级 Sound pressure level, L _{PA} dB
				满载 load 100%	3/4 负载 load 75%	1/2 负载 load 50%		I _N A	I _s /I _N	T _N Nm	T _l /T _N	T _b /T _N			
kW			r/min							CENELEC- 设计 design					
1500 r/min = 4 极 / 4 poles			380 V												
0.25	M2BAX 71 MB	3GBA 072 320-●●DCN	1432	73.5	71.6	66.2	0.69	0.76	5.8	1.67	2.5	3.1	0.00075	11	41
0.37	M2BAX 71 MLA	3GBA 072 410-●●DCN	1433	77.3	75.6	71.4	0.71	0.80	6.4	2.47	2.5	3.4	0.00098	13	50
0.55	M2BAX 80 MC	3GBA 082 330-●●DCN	1438	80.8	81.4	79.4	0.77	1.34	7.7	3.66	1.9	3.5	0.00228	15	48
0.75	M2BAX 80 MLA	3GBA 082 410-●●DCN	1438	82.5	81.8	79.2	0.74	1.83	7.6	4.88	3.4	4.2	0.00295	24	48
1.1	M2BAX 90 SB	3GBA 092 120-●●DCN	1431	84.1	83.8	82.3	0.77	2.58	7.3	7.27	3.2	3.7	0.00394	22	47
1.5	M2BAX 90 SLA	3GBA 092 010-●●DCN	1432	85.3	85.0	83.4	0.77	3.50	7.7	9.96	3.9	4.5	0.00485	24	44
2.2	M2BAX 100 LB	3GBA 102 520-●●DCN	1444	86.7	87.1	85.5	0.81	4.81	7.9	14.6	3.1	3.9	0.00863	35	50
3	M2BAX 100 LKA	3GBA 102 810-●●DCN	1443	87.7	88.1	87.6	0.82	6.35	8.0	19.9	3.2	4.1	0.0115	43	56
4	M2BAX 112 MLA	3GBA 112 410-●●DCN	1436	88.6	89.9	90.1	0.83	8.25	7.9	26.7	3.2	3.9	0.0152	53	56
5.5	M2BAX 132 SMA	3GBA 132 210-●●DCN	1459	89.6	90.9	91.1	0.79	11.7	7.4	36.0	2.3	3.0	0.0297	68	68
7.5	M2BAX 132 MLA	3GBA 132 410-●●DCN	1452	90.4	91.5	91.6	0.81	15.5	7.9	49.1	2.3	2.7	0.039	87	65
11	M2BAX 160 MLA	3GBA 162 410-●●FCN	1474	91.4	91.9	91.5	0.83	21.9	6.9	71.5	2.3	3.0	0.110	139	61
15	M2BAX 160 MLB	3GBA 162 420-●●FCN	1474	92.1	92.6	92.1	0.84	29.4	7.5	97.2	2.6	3.2	0.135	171	61
18.5	M2BAX 180 MLA	3GBA 182 410-●●FCN	1469	92.6	92.9	92.8	0.84	36.3	8.5	120	3.2	3.6	0.135	155	64
22	M2BAX 180 MLB	3GBA 182 420-●●FCN	1469	93.0	93.3	93.2	0.83	43.8	8.4	143	3.0	3.8	0.167	207	65
30	M2BAX 200 MLA	3GBA 202 410-●●FCN	1479	93.6	94.1	93.9	0.84	58.5	8.0	193	3.3	2.7	0.320	170	68
37	M2BAX 225 SMA	3GBA 222 210-●●FCN	1476	93.9	94.4	94.3	0.84	71.8	7.9	237	2.2	2.7	0.376	282	67
45	M2BAX 225 SMB	3GBA 222 220-●●FCN	1478	94.2	94.6	94.5	0.82	88.7	7.9	289	3.7	3.2	0.415	290	68
55	M2BAX 250 SMA	3GBA 252 210-●●FCN	1475	94.6	94.9	94.8	0.86	103	7.9	353	3.5	2.9	0.620	400	74
75	M2BAX 280 SMB	3GBA 282 220-●●MCN	1483	95.0	95.2	94.9	0.87	138	5.8	483	2.1	2.5	1.4	573	75
90	M2BAX 280 SMC	3GBA 282 230-●●MCN	1483	95.2	95.6	95.5	0.87	166	6.4	580	2.2	2.6	1.7	636	75
110	M2BAX 315 SMB	3GBA 312 220-●●MCN	1488	95.4	95.5	95.0	0.86	201	6.3	705	1.9	2.7	2.4	823	71
132	M2BAX 315 SMC	3GBA 312 230-●●MCN	1487	95.6	95.8	95.7	0.87	242	6.1	848	1.9	2.6	2.9	892	71
160	M2BAX 315 SMD	3GBA 312 240-●●MCN	1487	95.8	96.0	95.7	0.86	295	6.3	1026	2.0	2.7	3.2	933	71
200	M2BAX 315 MLB	3GBA 312 420-●●MCN	1485	96.0	96.3	96.2	0.87	364	6.1	1284	2.1	2.7	3.9	1091	74
250	M2BAX 355 SMA	3GBA 352 210-●●MCN	1490	96.0	96.0	95.6	0.87	452	5.8	1601	1.9	2.6	5.9	1445	78
315	M2BAX 355 SMB	3GBA 352 220-●●MCN	1491	96.0	96.2	95.7	0.86	578	6.6	2018	2.1	3.0	6.9	1595	78
355	M2BAX 355 SMC	3GBA 352 230-●●MCN	1490	96.0	96.3	96.1	0.87	643	5.7	2273	2.1	2.5	7.2	1635	78

产品代码中的两个圆点表示可选的安装方式、电压及频率代码（见订购信息一页）。

The two bullets in the product code indicate choice of mounting arrangements, voltage and frequency code (see ordering information page).

根据 IEC 60034-2-1 edition 2.0, 2014-06 的要求, 给出效率值。

请注意, 在测试方法未知时, 这些数值没有可比性。

ABB 已经根据间接法计算出效率值, 且根据测量得出杂散损耗 (附加损耗)。

Efficiency values are given according to IEC 60034-2-1 edition 2.0, 2014-06.

Please note that the values are not comparable without knowing the testing method.

ABB has calculated the efficiency values according to indirect method, stray load losses (additional losses) determined from measuring.

I_s / I_N = 启动电流

T_l / T_N = 转子堵转转矩

T_b / T_N = 最大转矩

I_s / I_N = Starting current

T_l / T_N = Locked rotor torque

T_b / T_N = Breakdown torque

三相全封闭鼠笼式电机的技术数据

Technical data for totally enclosed squirrel cage three phase motors

IP 55 – IC 411 – 绝缘等级 F, 温升等级 B

符合 IEC 60034-30-1; 2014 的 IE3 效率等级及 GB 18613-2012 的 2 级能效

IP 55 - IC 411 - Insulation class F, temperature rise class B

IE3 efficiency class according to IEC 60034-30-1; 2014 , Grade 2 according to GB 18613-2012

输出 Output	电机型号 Motor type	产品代码 Product code	转速 Speed	效率 / Efficiency IEC 60034-2-1; 2007			功率 因数 Power factor	电流 Current		转矩 / Torque			转动惯量 Moment of inertia	重量 Weight	声压等级 Sound pressure level, L _{PA} dB
				满载 load 100%	3/4 负载 load 75%	1/2 负载 load 50%		I _N A	I _s /I _N	T _N Nm	T _l /T _N	T _b /T _N			
kW			r/min				cos φ					J=1/4 GD ² kgm ²	kg		
1500 r/min = 4 极 / 4 poles			400 V	CENELEC- 设计 design											
0.25	M2BAX 71 MB	3GBA 072 320-••DCN	1440	73.5	70.1	63.8	0.64	0.78	6.1	1.67	2.7	3.5	0.00075	11	41
0.37	M2BAX 71 MLA	3GBA 072 410-••DCN	1441	77.3	74.9	69.8	0.66	1.06	6.8	2.47	2.7	3.8	0.00098	13	50
0.55	M2BAX 80 MC	3GBA 082 330-••DCN	1446	80.8	80.7	78.0	0.74	1.32	8.0	3.64	2.7	3.9	0.00228	15	48
0.75	M2BAX 80 MLA	3GBA 082 410-••DCN	1445	82.5	81.2	77.6	0.70	1.84	7.8	4.88	3.8	4.6	0.00295	24	49
1.1	M2BAX 90 SB	3GBA 092 120-••DCN	1438	84.1	83.4	80.9	0.73	2.59	7.9	7.28	3.6	4.2	0.00394	22	48
1.5	M2BAX 90 SLA	3GBA 092 010-••DCN	1439	85.3	84.4	82.1	0.73	3.52	7.8	9.95	3.9	4.5	0.00485	24	44
2.2	M2BAX 100 LB	3GBA 102 520-••DCN	1450	86.7	86.1	84.1	0.78	4.74	8.4	14.5	3.4	4.4	0.00863	35	50
3	M2BAX 100 LKA	3GBA 102 810-••DCN	1448	87.7	87.7	86.5	0.79	6.25	8.6	19.9	3.6	4.5	0.0115	43	57
4	M2BAX 112 MLA	3GBA 112 410-••DCN	1443	88.6	88.9	88.1	0.81	8.11	8.5	26.5	3.6	4.4	0.0152	53	57
5.5	M2BAX 132 SMA	3GBA 132 210-••DCN	1463	89.6	90.4	90.2	0.77	11.5	7.9	35.9	2.6	3.3	0.0297	68	68
7.5	M2BAX 132 MLA	3GBA 132 410-••DCN	1456	90.4	91.1	90.8	0.78	15.2	8.2	49.1	2.5	3.0	0.039	87	65
11	M2BAX 160 MLA	3GBA 162 410-••FCN	1477	91.4	91.8	91.1	0.82	21.1	7.6	71.3	2.6	3.3	0.110	139	61
15	M2BAX 160 MLB	3GBA 162 420-••FCN	1477	92.1	92.4	91.6	0.82	28.5	7.8	97.0	3.0	3.7	0.135	171	61
18.5	M2BAX 180 MLA	3GBA 182 410-••FCN	1472	92.6	92.6	92.0	0.82	35.0	9.3	120	3.6	4.0	0.135	155	64
22	M2BAX 180 MLB	3GBA 182 420-••FCN	1473	93.0	93.2	92.5	0.80	42.8	9.1	143	3.3	4.2	0.167	207	65
30	M2BAX 200 MLA	3GBA 202 410-••FCN	1481	93.6	94.0	93.5	0.82	56.3	9.0	193	3.9	3.0	0.320	170	69
37	M2BAX 225 SMA	3GBA 222 210-••FCN	1479	93.9	94.2	93.7	0.81	70.3	8.4	238	2.5	3.0	0.376	282	67
45	M2BAX 225 SMB	3GBA 222 220-••FCN	1481	94.2	94.4	93.8	0.79	87.8	8.2	288	4.2	3.6	0.415	290	68
55	M2BAX 250 SMA	3GBA 252 210-••FCN	1479	94.6	94.7	94.0	0.83	102	8.3	352	4.4	3.4	0.620	400	74
75	M2BAX 280 SMB	3GBA 282 220-••MCN	1485	95.0	95.2	94.8	0.86	133	6.4	483	2.3	2.8	1.4	573	75
90	M2BAX 280 SMC	3GBA 282 230-••MCN	1485	95.2	95.3	94.8	0.86	159	7.1	588	2.5	2.9	1.7	636	75
110	M2BAX 315 SMB	3GBA 312 220-••MCN	1489	95.4	95.4	94.8	0.85	196	7.0	705	2.1	3.0	2.4	823	71
132	M2BAX 315 SMC	3GBA 312 230-••MCN	1488	95.6	95.8	95.3	0.86	231	6.7	847	2.2	2.9	2.9	892	71
160	M2BAX 315 SMD	3GBA 312 240-••MCN	1488	95.8	96.0	95.8	0.85	282	6.9	1026	2.2	3.0	3.2	933	71
200	M2BAX 315 MLB	3GBA 312 420-••MCN	1487	96.0	96.4	96.4	0.86	351	6.8	1284	2.4	3.0	3.9	1091	74
250	M2BAX 355 SMA	3GBA 352 210-••MCN	1491	96.0	96.0	95.6	0.86	435	6.4	1601	2.1	2.9	5.9	1445	78
315	M2BAX 355 SMB	3GBA 352 220-••MCN	1491	96.0	96.0	95.6	0.86	545	6.7	2018	2.3	3.0	6.9	1595	78
355	M2BAX 355 SMC	3GBA 352 230-••MCN	1490	96.0	96.2	95.8	0.86	616	6.3	2273	2.3	2.8	7.2	1635	78

产品代码中的两个圆点表示可选的安装方式、电压及频率代码（见订购信息一页）。

The two bullets in the product code indicate choice of mounting arrangements, voltage and frequency code (see ordering information page).

根据 IEC 60034-2-1 edition 2.0, 2014-06 的要求, 给出效率值。

请注意, 在测试方法未知时, 这些数值没有可比性。

ABB 已经根据间接法计算出效率值, 且根据测量得出杂散损耗 (附加损耗)。

Efficiency values are given according to IEC 60034-2-1 edition 2.0, 2014-06.

Please note that the values are not comparable without knowing the testing method.

ABB has calculated the efficiency values according to indirect method, stray load losses (additional losses) determined from measuring.

I_s / I_N = 启动电流

T_l / T_N = 转子堵转转矩

T_b / T_N = 最大转矩

I_s / I_N = Starting current

T_l / T_N = Locked rotor torque

T_b / T_N = Breakdown torque

三相全封闭鼠笼式电机的技术数据

Technical data for totally enclosed squirrel cage three phase motors

IP 55 – IC 411 – 绝缘等级 F，温升等级 B

符合 IEC 60034-30-1; 2014 的 IE3 效率等级及 GB 18613-2012 的 2 级能效

IP 55 - IC 411 - Insulation class F, temperature rise class B

IE3 efficiency class according to IEC 60034-30-1; 2014 , Grade 2 according to GB 18613-2012

输出 Output	电机型号 Motor type	产品代码 Product code	转速 Speed	效率 / Efficiency IEC 60034-2-1; 2007			功率 因数 Power factor cos φ	电流 Current			转矩 / Torque		转动惯量 Moment of inertia J=1/4 GD ² kgm ²	重量 Weight kg	声压等级 Sound pressure level, L _{PA} dB
				满载 load 100%	3/4 负载 load 75%	1/2 负载 load 50%		I _N A	I _s /I _N	T _N Nm	T _l /T _N	T _b /T _N			
kW			r/min					CENELEC- 设计 design							
1000 r/min = 6 极 / 6 poles			380 V												
0.18	M2BAX 71 MB	3GBA 073 320-●●DCN	922	63.9	60.8	54.9	0.73	0.59	3.8	1.87	1.9	2.3	0.00103	10	39
0.25	M2BAX 71 MLA	3GBA 073 410-●●DCN	915	68.6	67.3	63.0	0.71	0.80	3.8	2.58	2.4	2.6	0.0014	13	46
0.37	M2BAX 80 MC	3GBA 083 330-●●DCN	930	73.5	72.4	68.8	0.70	1.09	5.4	3.80	2.5	2.9	0.00240	15	42
0.55	M2BAX 80 MLA	3GBA 083 410-●●DCN	934	77.2	76.8	73.7	0.71	1.54	5.9	5.61	3.0	3.1	0.00353	20	47
0.75	M2BAX 90 SLA	3GBA 093 010-●●DCN	946	78.9	78.9	75.8	0.63	2.32	5.1	7.57	2.8	3.3	0.00440	22	50
1.1	M2BAX 90 LB	3GBA 093 520-●●DCN	948	81.0	79.9	76.8	0.66	3.14	5.7	11.1	3.0	3.5	0.00643	30	53
1.5	M2BAX 100 LKA	3GBA 103 810-●●DCN	947	82.5	84.2	83.7	0.90	3.10	5.4	15.1	2.1	2.7	0.00975	38	59
2.2	M2BAX 112 MLA	3GBA 113 410-●●DCN	951	84.3	84.3	82.9	0.68	5.90	6.2	22.0	2.6	3.3	0.01300	47	49
3	M2BAX 132 SMA	3GBA 133 210-●●DCN	964	85.6	86.8	86.2	0.73	7.31	6.4	29.7	1.9	2.8	0.02910	66	48
4	M2BAX 132 SMB	3GBA 133 220-●●DCN	968	86.8	87.4	86.1	0.69	10.2	6.6	39.5	2.5	3.1	0.03430	73	52
5.5	M2BAX 132 MLA	3GBA 133 410-●●DCN	971	88.0	88.2	87.5	0.70	13.5	6.8	54.3	2.6	3.2	0.051	103	64
7.5	M2BAX 160 MLA	3GBA 163 410-●●FCN	976	89.1	89.7	89.8	0.78	16.3	7.0	73.7	1.6	2.8	0.099	138	58
11	M2BAX 160 MLB	3GBA 163 420-●●FCN	973	90.3	91.6	91.9	0.80	23.3	7.0	108	1.6	2.7	0.134	173	57
15	M2BAX 180 MLA	3GBA 183 410-●●FCN	968	91.2	92.0	91.8	0.78	32.4	7.7	146	2.0	3.3	0.162	208	62
18.5	M2BAX 200 MLA	3GBA 203 410-●●FCN	975	91.7	92.5	92.3	0.78	39.6	6.1	181	1.9	2.5	0.207	203	64
22	M2BAX 200 MLB	3GBA 203 420-●●FCN	974	92.2	92.8	92.5	0.78	46.9	6.6	214	2.0	2.7	0.255	212	61
30	M2BAX 225 SMA	3GBA 223 210-●●FCN	985	92.9	93.5	93.2	0.82	60.1	7.8	289	2.7	3.0	0.592	284	63
37	M2BAX 250 SMA	3GBA 253 210-●●FCN	985	93.3	93.9	93.7	0.81	74.3	7.7	354	2.8	2.7	0.830	363	64
45	M2BAX 280 SMB	3GBA 283 220-●●MCN	989	93.7	94.1	93.7	0.85	85.3	6.7	433	2.4	2.7	1.9	562	72
55	M2BAX 280 SMC	3GBA 283 230-●●MCN	992	94.1	94.5	94.3	0.86	103	6.8	530	2.5	2.7	2.6	615	71
75	M2BAX 315 SMB	3GBA 313 220-●●MCN	993	94.6	94.9	94.5	0.85	142	6.1	720	1.6	2.3	4.1	791	75
90	M2BAX 315 SMC	3GBA 313 230-●●MCN	993	94.9	95.1	94.5	0.85	169	6.5	864	1.8	2.7	4.6	859	76
110	M2BAX 315 SMD	3GBA 313 240-●●MCN	993	95.1	95.3	94.8	0.84	209	6.6	1056	1.9	2.8	4.9	912	75
132	M2BAX 315 MLB	3GBA 313 420-●●MCN	994	95.4	95.5	94.9	0.84	250	6.4	1266	2.0	2.9	6.3	1068	72
160	M2BAX 355 SMA	3GBA 353 210-●●MCN	992	95.6	96.0	95.9	0.86	294	6.0	1538	2.2	2.3	7.9	1348	75
200	M2BAX 355 SMB	3GBA 353 220-●●MCN	992	95.8	96.2	96.2	0.83	382	6.0	1923	2.3	2.2	9.7	1512	75
250	M2BAX 355 SMC	3GBA 353 230-●●MCN	992	95.8	96.2	95.8	0.83	475	7.0	2404	2.7	2.8	11.3	1656	75

产品代码中的两个圆点表示可选的安装方式、电压及频率代码（见订购信息一页）。

The two bullets in the product code indicate choice of mounting arrangements, voltage and frequency code (see ordering information page).

根据 IEC 60034-2-1 edition 2.0, 2014-06 的要求，给出效率值。

请注意，在测试方法未知时，这些数值没有可比性。

ABB 已经根据间接法计算出效率值，且根据测量得出杂散损耗（附加损耗）。

Efficiency values are given according to IEC 60034-2-1 edition 2.0, 2014-06.

Please note that the values are not comparable without knowing the testing method.

ABB has calculated the efficiency values according to indirect method, stray load losses (additional losses) determined from measuring.

I_s / I_N = 启动电流

T_l / T_N = 转子堵转转矩

T_b / T_N = 最大转矩

I_s / I_N = Starting current

T_l / T_N = Locked rotor torque

T_b / T_N = Breakdown torque

三相全封闭鼠笼式电机的技术数据

Technical data for totally enclosed squirrel cage three phase motors

IP 55 – IC 411 – 绝缘等级 F，温升等级 B

符合 IEC 60034-30-1; 2014 的 IE3 效率等级及 GB 18613-2012 的 2 级能效

IP 55 - IC 411 - Insulation class F, temperature rise class B

IE3 efficiency class according to IEC 60034-30-1; 2014 , Grade 2 according to GB 18613-2012

输出 Output	电机型号 Motor type	产品代码 Product code	转速 Speed	效率 / Efficiency IEC 60034-2-1; 2007			功率 因数 Power factor cos φ	电流 Current		转矩 / Torque			转动惯量 Moment of inertia J=1/4 GD ² kgm ²	重量 Weight kg	声压等级 Sound pressure level, L _{PA} dB
				满载 load 100%	3/4 负载 load 75%	1/2 负载 load 50%		I _N A	I _s /I _N	T _N Nm	T _l /T _N	T _b /T _N			
kW			r/min												
1000 r/min = 6 极 / 6 poles			400 V				CENELEC- 设计 design								
0.18	M2BAX 71 MB	3GBA 073 320-••DCN	931	63.9	60.0	53.2	0.69	0.60	3.8	1.87	2.1	2.6	0.00103	10	39
0.25	M2BAX 71 MLA	3GBA 073 410-••DCN	926	68.6	66.3	60.9	0.67	0.80	4.3	2.58	2.6	2.9	0.0014	13	46
0.37	M2BAX 80 MC	3GBA 083 330-••DCN	939	73.5	71.5	66.7	0.66	1.09	5.6	3.80	2.8	3.2	0.0024	15	42
0.55	M2BAX 80 MLA	3GBA 083 410-••DCN	943	77.2	75.9	71.9	0.68	1.54	6.3	5.60	3.4	3.5	0.00353	20	48
0.75	M2BAX 90 SLA	3GBA 093 010-••DCN	952	78.9	78.0	73.9	0.59	2.35	5.3	7.52	3.1	3.6	0.0044	22	50
1.1	M2BAX 90 LB	3GBA 093 520-••DCN	954	81.0	80.3	75.5	0.62	3.20	6.1	11.1	3.3	3.9	0.00643	30	53
1.5	M2BAX 100 LKA	3GBA 103 810-••DCN	953	82.5	83.4	82.0	0.88	3.00	5.9	15.0	2.4	3.0	0.00975	38	59
2.2	M2BAX 112 MLA	3GBA 113 410-••DCN	957	84.3	83.8	81.5	0.64	5.94	6.5	22.0	2.9	3.7	0.013	47	50
3	M2BAX 132 SMA	3GBA 133 210-••DCN	968	85.6	86.1	84.9	0.68	7.40	6.7	29.6	2.1	3.2	0.0291	66	48
4	M2BAX 132 SMB	3GBA 133 220-••DCN	972	86.8	86.8	84.9	0.65	10.1	7.0	39.3	2.7	3.6	0.0343	73	52
5.5	M2BAX 132 MLA	3GBA 133 410-••DCN	974	88.0	87.4	86.0	0.67	13.5	7.3	54.2	2.9	3.5	0.051	103	65
7.5	M2BAX 160 MLA	3GBA 163 410-••FCN	979	89.1	89.5	88.9	0.75	15.9	7.6	73.4	1.8	3.1	0.099	138	59
11	M2BAX 160 MLB	3GBA 163 420-••FCN	976	90.3	91.3	91.3	0.78	22.5	7.8	108	1.9	3.0	0.134	173	57
15	M2BAX 180 MLA	3GBA 183 410-••FCN	971	91.2	91.8	91.2	0.75	31.8	8.6	146	2.3	3.6	0.162	208	63
18.5	M2BAX 200 MLA	3GBA 203 410-••FCN	978	91.7	92.1	91.5	0.75	38.8	6.7	180	2.1	2.8	0.207	203	64
22	M2BAX 200 MLB	3GBA 203 420-••FCN	978	92.2	92.5	91.8	0.75	45.9	7.3	214	2.3	3.0	0.255	212	62
30	M2BAX 225 SMA	3GBA 223 210-••FCN	988	92.9	93.3	92.7	0.79	59.0	7.8	290	2.9	3.3	0.592	284	63
37	M2BAX 250 SMA	3GBA 253 210-••FCN	986	93.3	93.6	93.1	0.79	72.4	8.1	353	3.3	3.0	0.830	363	64
45	M2BAX 280 SMB	3GBA 283 220-••MCN	991	93.7	94.0	93.5	0.84	81.9	7.4	433	2.7	3.0	1.9	562	72
55	M2BAX 280 SMC	3GBA 283 230-••MCN	993	94.1	94.3	93.8	0.86	98.2	7.5	530	2.8	3.0	2.6	615	71
75	M2BAX 315 SMB	3GBA 313 220-••MCN	994	94.6	94.9	94.6	0.84	136	6.8	720	1.8	2.6	4.1	791	75
90	M2BAX 315 SMC	3GBA 313 230-••MCN	994	94.9	95.1	94.7	0.84	164	7.2	864	2.0	3.0	4.6	859	76
110	M2BAX 315 SMD	3GBA 313 240-••MCN	994	95.1	95.3	95.0	0.83	200	7.3	1056	2.2	3.1	4.9	912	75
132	M2BAX 315 MLB	3GBA 313 420-••MCN	995	95.4	95.5	95.1	0.82	242	7.3	1266	2.3	3.2	6.3	1068	72
160	M2BAX 355 SMA	3GBA 353 210-••MCN	993	95.6	95.9	95.6	0.82	292	6.7	1538	2.5	2.6	7.9	1348	75
200	M2BAX 355 SMB	3GBA 353 220-••MCN	993	95.8	96.2	96.1	0.82	365	6.7	1923	2.6	2.5	9.7	1512	75
250	M2BAX 355 SMC	3GBA 353 230-••MCN	993	95.8	96.1	95.8	0.81	464	7.7	2404	3.0	3.1	11.3	1656	75

产品代码中的两个圆点表示可选的安装方式、电压及频率代码（见订购信息一页）。

The two bullets in the product code indicate choice of mounting arrangements, voltage and frequency code (see ordering information page).

根据 IEC 60034-2-1 edition 2.0, 2014-06 的要求，给出效率值。

请注意，在测试方法未知时，这些数值没有可比性。

ABB 已经根据间接法计算出效率值，且根据测量得出杂散损耗（附加损耗）。

Efficiency values are given according to IEC 60034-2-1 edition 2.0, 2014-06.

Please note that the values are not comparable without knowing the testing method.

ABB has calculated the efficiency values according to indirect method, stray load losses (additional losses) determined from measuring.

I_s / I_N = 启动电流

T_l / T_N = 转子堵转转矩

T_b / T_N = 最大转矩

I_s / I_N = Starting current

T_l / T_N = Locked rotor torque

T_b / T_N = Breakdown torque

外形图及外形尺寸 Dimension drawings

机座号 71-132 Frame size 71-132

底脚安装型电机 IM1001, B3 Foot-mounted motor IM1001, B3

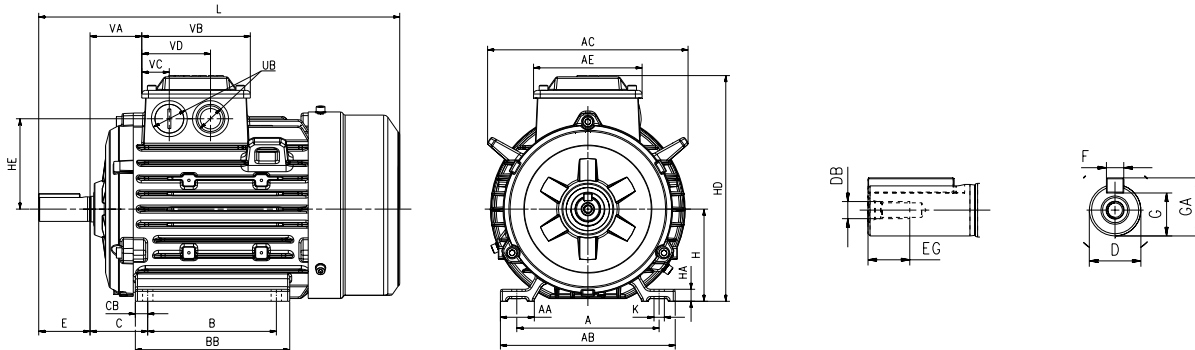

电机尺寸 Motor size		A	AA	AB	AC	AE	B	B'	BB	C	CB	D-tol.	DB	E	EG
M2BAX	71M	112	30	136	147	96	90	-	110	45	10	14-j6	M5	30	12.5
	71ML	112	30	136	147	96	90	-	135	45	10	14-j6	M5	30	12.5
	80M	125	33	154	161	106	100	-	125	50	12.5	19-j6	M6	40	16
	80ML	125	33	154	161	106	100	112	150	50	12.5	19-j6	M6	40	16
	90S	140	33	170	195	106	100	-	124	56	12	24-j6	M8	50	19
	90SL	140	33	170	195	106	100	125	150	56	12	24-j6	M8	50	19
	90L ¹⁾	140	33	170	195	106	125	-	150	56	12	24-j6	M8	50	19
	90L ²⁾	140	33	170	195	106	125	-	185	56	12	24-j6	M8	50	19
	100L	160	38	200	218	122	140	-	170	63	15	28-j6	M10	60	22
	100LK	160	38	200	218	122	140	160	205	63	15	28-j6	M10	60	22
	112M	190	48	230	218	122	140	-	170	70	15	28-j6	M10	60	22
	112ML	190	48	230	218	122	140	159	215	70	15	28-j6	M10	60	22
	132S	216	53	262	270	122	140	-	170	89	16	38-k6	M12	80	28
	132SM	216	53	262	270	122	140	178	210	89	16	38-k6	M12	80	28
132M	216	53	262	270	122	178	-	210	89	16	38-k6	M12	80	28	
132ML	216	53	262	270	122	178	203	275	89	16	38-k6	M12	80	28	

电机尺寸 Motor size		F	G	GA	H	HA	HE	HD	K	L	UB	VA	VB	VC	VD
M2BAX	71M	5	11	16	71	9	65	175	7	257	M16x1.5	40	96	32	64
	71ML	5	11	16	71	9	65	175	7	282	M16x1.5	40	96	32	64
	80M	6	15.5	21.5	80	12	72	192	10	309	M25x1.5	43	106	33	73
	80ML	6	15.5	21.5	80	12	72	192	10	334	M25x1.5	43	106	33	73
	90S	8	20	27	90	12	88	217	10	335	M25x1.5	50	106	33	73
	90SL	8	20	27	90	12	88	217	10	351	M25x1.5	50	106	33	73
	90L ¹⁾	8	20	27	90	12	88	217	10	351	M25x1.5	50	106	33	73
	90L ²⁾	8	20	27	90	12	88	217	10	386	M25x1.5	50	106	33	73
	100L	8	24	31	100	15	100	240	12	376	M32x1.5	55	122	37	84
	100LK	8	24	31	100	15	100	240	12	411	M32x1.5	55	122	37	84
	112M	8	24	31	112	15	100	252	12	411	M32x1.5	55	122	37	84
	112ML	8	24	31	112	15	100	252	12	456	M32x1.5	55	122	37	84
	132S	10	33	41	132	18	129	302	12	479	M32x1.5	65	122	37	84
	132SM	10	33	41	132	18	129	302	12	521	M32x1.5	65	122	37	84
132M	10	33	41	132	18	129	302	12	521	M32x1.5	65	122	37	84	
132ML	10	33	41	132	18	129	302	12	586	M32x1.5	65	122	37	84	

公差 Tolerance	附注 Footnotes
A, B ± 0.8	¹⁾ M2BAX IE2
D ISO j6 ≤ φ 28 mm ISO k6 ≤ φ 38 mm	²⁾ M2BAX IE3
F ISO h9	
H +0, -0.5	
N ISO j6	
C ± 0.8	

上表给出了主要尺寸 (单位: mm)
如需图纸详情, 请访问我们的网页
www.abb.com/motorsandgenerators 或联系 ABB。

Above table gives the main dimensions in mm.
For detailed drawings please see our web-pages
www.abb.com/motorsandgenerators or contact ABB.

外形图及外形尺寸 Dimension drawings

机座号 71-132 Frame size 71-132

凸缘安装型电机 IM3001, B5
Flange-mounted motor IM3001, B5

小凸缘安装型电机 IM3601, B14
Small flange-mounted motor IM3601, B14

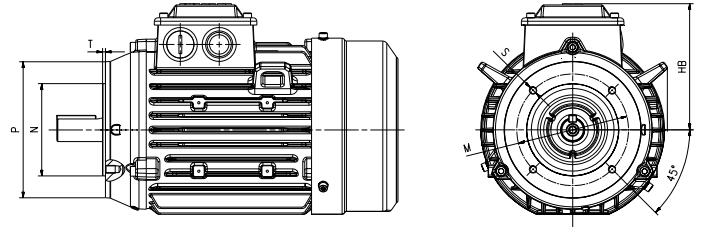
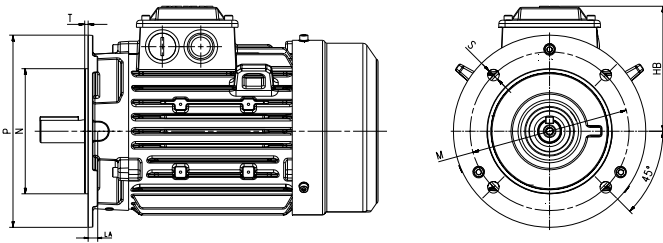

电机尺寸 Motor size		HB	LA	M	N	P	S	T
M2BAX	71M	104	9	130	110	160	10	3.5
	71ML	104	9	130	110	160	10	3.5
	80M	112	10	165	130	200	12	3.5
	80ML	112	10	165	130	200	12	3.5
	90S	127	10	165	130	200	12	3.5
	90SL	127	10	165	130	200	12	3.5
	90L ¹⁾	127	10	165	130	200	12	3.5
	90L ²⁾	127	10	165	130	200	12	3.5
	100L	141	11	215	180	250	14.5	4
	100LK	141	11	215	180	250	14.5	4
	112M	141	11	215	180	250	14.5	4
	112ML	141	11	215	180	250	14.5	4
	132S	170	12	265	230	300	14.5	4
	132SM	170	12	265	230	300	14.5	4
132M	170	12	265	230	300	14.5	4	
132ML	170	12	265	230	300	14.5	4	

电机尺寸 Motor size		M	N	P	S	T
M2BAX	71M	85	70	105	M6	2.5
	71ML	85	70	105	M6	2.5
	80M	100	80	120	M6	3
	80ML	100	80	120	M6	3
	90S	115	95	140	M8	3
	90SL	115	95	140	M8	3
	90L ¹⁾	115	95	140	M8	3
	90L ²⁾	115	95	140	M8	3
	100L	130	110	160	M8	3.5
	100LK	130	110	160	M8	3.5
	112M	130	110	160	M8	3.5
	112ML	130	110	160	M8	3.5
	132S	165	130	200	M10	3.5
	132SM	165	130	200	M10	3.5
132M	165	130	200	M10	3.5	
132ML	165	130	200	M10	3.5	

公差 Tolerance	附注 Footnotes
A, B ± 0.8	¹⁾ M2BAX IE2
D ISO j6 ≤ φ 28 mm ISO k6 ≤ φ 38 mm	²⁾ M2BAX IE3
F ISO h9	
H +0, -0.5	
N ISO j6	
C ± 0.8	

上表给出了主要尺寸 (单位: mm)
如需图纸详情, 请访问我们的网页
www.abb.com/motors&generators 或联系 ABB.

Above table gives the main dimensions in mm.
For detailed drawings please see our web-pages
www.abb.com/motors&generators or contact ABB.

外形图及外形尺寸 Dimension drawings

机座号 160-250 Frame size 160-250

底脚安装型电机 IM1001, B3
Foot-mounted motor IM1001, B3

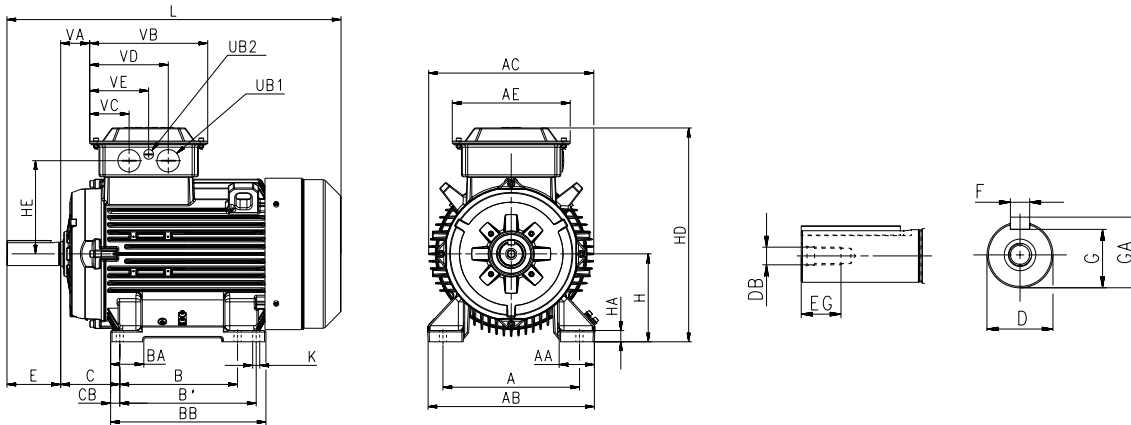

电机尺寸 Motor size	极数 Poles	A	AA	AB	AC	AE	B	B'	BA	BB	C	CB	D-tol.	DB	E	EG
M2BAX 160ML ¹⁾	2-6	254	67	310	338	241	210	254	69	294	108	20	42-k6	M16	110	36
160ML ²⁾	2-6	254	67	310	338	241	210	254	69	294	108	20	42-k6	M16	110	36
160ML ³⁾	2-6	254	67	310	338	241	210	254	69	294	108	20	42-k6	M16	110	36
180ML ⁴⁾	2-6	279	72	340	338	241	241	279	68	318	121	19	48-k6	M16	110	36
180ML ⁵⁾	2-6	279	72	340	338	241	241	279	68	378	121	19	48-k6	M16	110	36
200ML ⁶⁾	2-6	318	77	378	382	241	267	305	82	345	133	20	55-m6	M20	110	42
200ML ⁷⁾	2-6	318	77	378	382	241	267	305	82	445	133	20	55-m6	M20	110	42
225SM	2	356	91	435	414	262	286	311	69	351	149	20	55-m6	M20	110	42
225SM	4-6	356	91	435	414	262	286	311	69	351	149	20	60-m6	M20	140	42
250SM	2	406	98	480	462	262	311	349	72	392	168	22	60-m6	M20	140	42
250SM ⁸⁾	4-6	406	98	480	462	262	311	349	72	392	168	22	65-m6	M20	140	42
250SM ⁹⁾	4-6	406	98	480	462	262	311	349	72	437	168	22	65-m6	M20	140	42

电机尺寸 Motor size	极数 Poles	F	G	GA	H	HA	HD	HE	K	L	UB1	UB2	VA	VB	VC	VD	VE
M2BAX 160ML ¹⁾	2-6	12	37	45	160	23	413	188	14.5	586.5	M40x1.5	M16x1.5	59	241	81	161	120.5
160ML ²⁾	2-6	12	37	45	160	23	413	188	14.5	626.5	M40x1.5	M16x1.5	59	241	81	161	120.5
160ML ³⁾	2-6	12	37	45	160	23	413	188	14.5	683.5	M40x1.5	M16x1.5	59	241	81	161	120.5
180ML ⁴⁾	2-6	14	42.5	51.5	180	23	434	188	14.5	683.5	M40x1.5	M16x1.5	59	241	81	161	120.5
180ML ⁵⁾	2-6	14	42.5	51.5	180	23	434	188	14.5	743.5	M40x1.5	M16x1.5	59	241	81	161	120.5
200ML ⁶⁾	2-6	16	49	59	200	23	473	208	18.5	728	M40x1.5	M16x1.5	70	241	81	161	120.5
200ML ⁷⁾	2-6	16	49	59	200	23	473	208	18.5	828	M40x1.5	M16x1.6	70	241	81	161	120.5
225SM	2	16	49	59	225	23	539	228	18.5	824	M63x1.5	M16x1.7	79	262	83	179	131
225SM	4-6	18	53	64	225	23	539	228	18.5	854	M63x1.5	M16x1.8	79	262	83	179	131
250SM	2	18	53	64	250	23	585	248	24	882	M63x1.5	M16x1.9	72	262	83	179	131
250SM ⁸⁾	4-6	18	53	69	250	23	585	248	24	882	M63x1.5	M16x1.5	72	262	83	179	131
250SM ⁹⁾	4-6	18	53	69	250	23	585	248	24	927	M63x1.5	M16x1.5	72	262	83	179	131

公差 Tolerance

A, B	± 0.8
D	ISO k6 ≤ φ 50 mm ISO m6 ≤ φ 50 mm
F	ISO h9
H	+0, -0.5
N	ISO j6
C	± 0.8

附注 Footnotes

M2BAX IE2:	M2BAX IE3:
¹⁾ MLB6 以外其余型号	¹⁾ MLA2, MLB2
²⁾ All types except MLB6	²⁾ MLA4, MLA6
³⁾ MLB6	³⁾ MLC2, MLB4, MLB6
⁴⁾ 所有型号 All types	⁴⁾ MLA2, MLA4
⁵⁾ 所有型号 All types	⁵⁾ MLB4, MLA6
⁶⁾ 所有型号 All types	⁶⁾ MLA6
	⁷⁾ MLA6 以外其余型号
	All types except MLA6
	⁹⁾ 所有型号 All types

上表给出了主要尺寸 (单位: mm)
如需图纸详情, 请访问我们的网页
www.abb.com/motors&generators 或联系 ABB。

Above table gives the main dimensions in mm.
For detailed drawings please see our web-pages
www.abb.com/motors&generators or contact ABB.

外形图及外形尺寸 Dimension drawings

机座号 160-250 Frame size 160-250

凸缘安装型电机 IM3001, B5 Flange-mounted motor IM3001, B5

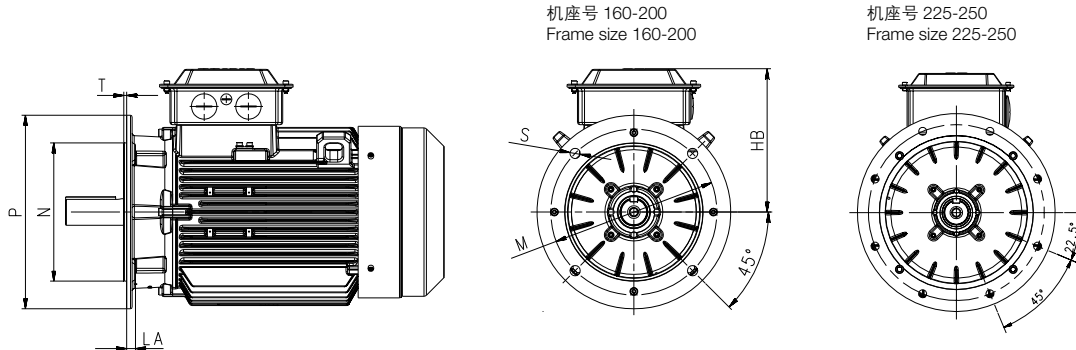

电机尺寸 Motor size	极数 Poles	HB	LA	M	N	P	S	T
M2BAX 160ML ¹⁾	2-6	253	16	300	250	350	18.5	5
160ML ²⁾	2-6	253	16	300	250	350	18.5	5
160ML ³⁾	2-6	253	16	300	250	350	18.5	5
180ML ⁴⁾	2-6	253	16	300	250	350	18.5	5
180ML ⁵⁾	2-6	253	16	300	250	350	18.5	5
200ML ⁶⁾	2-6	273	18	350	300	400	18.5	5
200ML ⁷⁾	2-6	273	18	350	300	400	18.5	5
225SM	2	314	20	400	350	450	18.5	5
225SM	4-6	314	20	400	350	450	18.5	5
250SM	2	334	22	500	450	550	18.5	5
250SM ⁸⁾	4-6	334	22	500	450	550	18.5	5
250SM ⁹⁾	4-6	334	22	500	450	550	18.5	5

公差 Tolerance

A, B	± 0.8
D	ISO k6 ≤ φ 50 mm ISO m6 ≤ φ 50 mm
F	ISO h9
H	+0, -0.5
N	ISO j6
C	± 0.8

附注 Footnotes

M2BAX IE2:	M2BAX IE3:
¹⁾ MLB6 以外其余型号 All types except MLB6	¹⁾ MLA2, MLB2
²⁾ MLB6	²⁾ MLA4, MLA6
⁴⁾ 所有型号 All types	³⁾ MLC2, MLB4, MLB6
⁵⁾ 所有型号 All types	⁴⁾ MLA2, MLA4
⁸⁾ 所有型号 All types	⁵⁾ MLB4, MLA6
	⁶⁾ MLA6
	⁷⁾ MLA6 以外其余型号 All types except MLA6
	⁹⁾ 所有型号 All types

上表给出了主要尺寸 (单位: mm)
如需图纸详情, 请访问我们的网页
www.abb.com/motors&generators 或联系 ABB。

Above table gives the main dimensions in mm.
For detailed drawings please see our web-pages
www.abb.com/motors&generators or contact ABB.

外形图及外形尺寸 Dimension drawings

机座号 280-355 Frame size 280-355

底脚安装型电机 IM1001, B3
Foot-mounted motor IM1001, B3

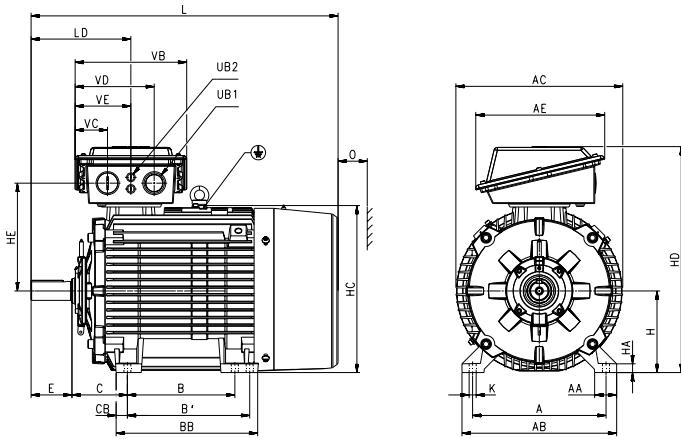

凸缘安装型电机 IM3001, B5
Flange-mounted motor IM3001, B5

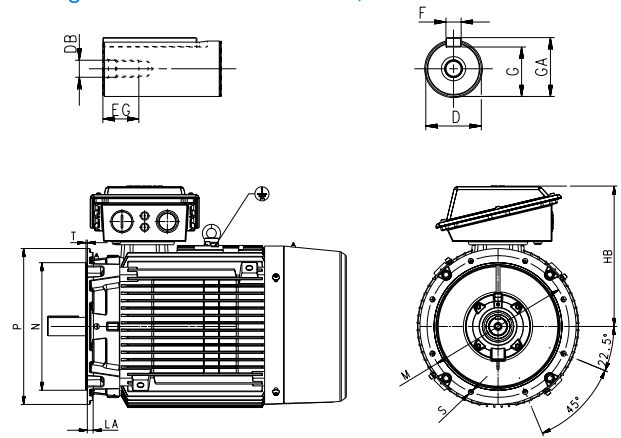

电机尺寸 Motor size	极数 Poles	A	AA	AB	AC	AE	B	B'	BB	C	CB	D-tol.	DB	E	EG	F	G
M2BAX 280SM ¹⁾	2	457	75	530	494	355	368	419	485	190	38	65-m6	M20	140	42	18	58
280SM ¹⁾	4-6	457	75	530	494	355	368	419	485	190	38	75-m6	M20	140	42	20	67.5
280SM ²⁾	2	457	75	530	571	442	368	419	485	190	38	65-m6	M20	140	42	18	58
280SM ²⁾	4-6	457	75	530	571	442	368	419	485	190	38	75-m6	M20	140	42	20	67.5
315SM	2	508	100	590	644	442	406	457	563	216	52	65-m6	M20	140	42	18	58
315SM	4-6	508	100	590	644	442	406	457	563	216	52	80-m6	M20	170	42	22	71
315ML	2	508	100	590	644	442	457	508	664	216	52	65-m6	M20	140	42	18	58
315ML	4-6	508	100	590	644	442	457	508	664	216	52	90-m6	M24	170	50	25	81
355SM	2	610	120	700	739	493	500	560	698	254	72	70-m6	M20	140	42	20	62.5
355SM	4-6	610	120	700	739	493	500	560	698	254	72	100-m6	M24	210	50	28	90

电机尺寸 Motor size	极数 Poles	GA	H	HA	HC	HD	HE	K	L	LD	O	UB1	UB2	VB	VC	VD	VE
M2BAX 280SM ¹⁾	2	69	280	30	544	710	319	24	1012	346	100	M63x1.5	M20x1.5	307	91	215	153.5
280SM ¹⁾	4-6	79.5	280	30	544	710	319	24	1012	346	100	M63x1.5	M20x1.5	307	91	215	153.5
280SM ²⁾	2	69	280	30	573	775	370	24	1052	342	100	M63x1.5	M20x1.5	383	111	271	191.5
280SM ²⁾	4-6	79.5	280	30	573	775	370	24	1052	342	100	M63x1.5	M20x1.5	383	111	271	191.5
315SM	2	69	315	38	638	849	409	28	1216	348	115	M63x1.5	M20x1.5	383	111	271	191.5
315SM	4-6	85	315	38	638	849	409	28	1246	378	115	M63x1.5	M20x1.5	383	111	271	191.5
315ML	2	69	315	38	638	849	409	28	1326	348	115	M63x1.5	M20x1.5	383	111	271	191.5
315ML	4-6	95	315	38	638	849	409	28	1356	378	115	M63x1.5	M20x1.5	383	111	271	191.5
355SM	2	74.5	355	41	725	933	462	35	1399	399	130	M75x1.5	M20x1.5	382	111	271	191.5
355SM	4-6	106	355	41	725	933	462	35	1469	469	130	M75x1.5	M20x1.5	382	111	271	191.5

电机尺寸 Motor size	极数 Poles	HB	LA	M	N	P	S	T
M2BAX 280SM ¹⁾	2-6	430	21	500	450	550	18.5	5
280SM ²⁾	2-6	495	21	500	450	550	18.5	6
315	2-6	534	27	600	550	660	24	6
355	2-6	578	22	740	680	800	24	6

公差 Tolerance

A, B	± 0.8
D	ISO k6 ≤ φ 50 mm ISO m6 ≤ φ 50 mm
F	ISO h9
H	+0, -1
N	ISO j6
C	± 0.8

附注 Footnotes

- ¹⁾ M2BAX IE2
²⁾ M2BAX IE3

上表给出了主要尺寸 (单位: mm)
如需图纸详情, 请访问我们的网页
www.abb.com/motors&generators 或联系 ABB。

Above table gives the main dimensions in mm.
For detailed drawings please see our web-pages
www.abb.com/motors&generators or contact ABB.

变量代码

Variant codes

代码 ¹⁾	变量代码	M2BAX													
Code ¹⁾	Variant code	71	80	90	100	112	132	160	180	200	225	250	280	315	355
轴承与润滑															
Bearings and Lubrication															
037	D 端圆柱滚子轴承 Roller bearing at D-end.	-	-	-	-	-	-	M/P	M/P	M/P	M/P	M/P	M/P	M/P	M/P
040	耐高温油脂 Heat-resistant grease.	P	P	P	P	P	P	P	P	P	P	P	P	P	P
041	可通过注油嘴润滑的轴承 Bearings regreasable via grease nipples.	-	R	R	R	R	R	M/P	M/P	M/P	M/P	M/P	S	S	S
043	SPM 振动测量接头 SPM compatible nipples for vibration measurement.	P	P	P	P	P	P	P	P	P	P	P	M/P	M/P	M/P
130	轴承安装 Pt100(三线) Pt100 3-wire in bearings.	-	-	-	-	-	-	P	P	P	P	P	P	P	P
188	D 端 63 系列轴承 63-series bearing in D-end.	-	P	P	P	P	P	P	P	P	P	P	P	P	P
379	SKF 轴承 SKF bearing.	P	P	P	P	P	P	P	P	P	P	P	P	P	P
其它应用标准设计															
Branch standard designs															
178	不锈钢 / 耐酸螺栓 Stainless steel / acid proof bolts.	M/P	M/P	M/P	M/P	M/P	M/P	M/P	M/P	M/P	M/P	M/P	M/P	M/P	M/P
209	非标准电压或频率 Non-standard voltage or frequency, (special winding).	P	P	P	P	P	P	P	P	P	P	P	P	P	P
冷却系统															
Cooling system															
068	轻合金金属风扇 Light alloy metal fan.	M/P	M/P	M/P	M/P	M/P	M/P	M/P	M/P	M/P	M/P	M/P	M/P	M/P	M/P
075	冷却方式 IC418 (无风扇) Cooling method IC418 (without fan).	P	P	P	P	P	P	P	P	P	P	P	P	P	P
183	独立电机冷却 (轴流风扇, N 端) Separate motor cooling (fan axial, N-end).	P	P	P	P	P	P	P	P	P	P	P	P	P	P
999F801	纺织风罩, 带网孔 Textile fan cover with holes.	P	P	P	P	P	P	-	-	-	-	-	-	-	-
999F802	纺织风罩, 不带网孔 Textile fan cover without holes.	P	P	P	P	P	P	-	-	-	-	-	-	-	-
文件材料															
Documentation															
141	配二维主要尺寸图 Binding 2D main dimension drawing.	M/P	M/P	M/P	M/P	M/P	M/P	M/P	M/P	M/P	M/P	M/P	M/P	M/P	M/P
接地螺栓															
Earthing Bolt															
067	外部接地螺栓 External earthing bolt.	S	S	S	S	S	S	S	S	S	S	S	S	S	S
加热元件															
Heating elements															
450	加热带, 100-120V Heating element, 100-120 V.	M/P	M/P	M/P	M/P	M/P	M/P	M/P	M/P	M/P	M/P	M/P	M/P	M/P	M/P
451	加热带, 200-240V Heating element, 200 - 240 V.	M/P	M/P	M/P	M/P	M/P	M/P	M/P	M/P	M/P	M/P	M/P	M/P	M/P	M/P
绝缘系统															
Insulation system															
014	H 级绝缘绕组 Winding insulation class H.	P	P	P	P	P	P	P	P	P	P	P	P	P	P
405	用于变频电源的特殊绕组绝缘 Special winding insulation for frequency converter supply.	P	P	P	P	P	P	P	P	P	P	P	P	P	P

¹⁾ 特定变量代码不能同时使用。

¹⁾ Certain variant codes cannot be used simultaneously.

代码 ¹⁾	变量代码	M2BAX														
Code ¹⁾	Variant code	71	80	90	100	112	132	160	180	200	225	250	280	315	355	
安装方式 Mounting arrangements																
008	IM2101 底脚 / 法兰安装, IEC 法兰, 由 IM1001 派生 (B3 派生出 B34) IM 2101 foot/flange mounted, IEC flange, from IM 1001 (B34 from B3).	M/P	M/P	M/P	M/P	M/P	M/P	M/P	-	-	-	-	-	-	-	
009	IM 2001 底脚 / 法兰安装, IEC 法兰, 由 IM1001 派生 (B3 派生出 B35) IM 2001 foot/flange mounted, IEC flange, from IM 1001 (B35 from B3).	M/P	M/P	M/P	M/P	M/P	M/P	M/P	M/P	M/P	M/P	M/P	M/P	M/P	M/P	
047	IM3601 法兰安装, IEC 法兰, 由 IM3001 派生 (B5 派生出 B14) IM 3601 flange mounted, IEC flange, from IM 3001 (B14 from B5).	M/P	M/P	M/P	M/P	M/P	M/P	M/P	-	-	-	-	-	-	-	
066	除 IM B3 (1001)、IM B5 (3001)、IM B14 (3601)、IM B35 (2001)、IM B34 (2101) 外的其它安装方式 Modified for specified mounting position differing from IM B3 (1001), IM B5 (3001), B14 (3601), IM B35 (2001), IM B34 (2101).	M/P	M/P	M/P	M/P	M/P	M/P	M/P	M/P	M/P	M/P	M/P	M/P	M/P	M/P	
320	IM2001 底脚 / 缺边法兰安装, 由 IM1001 派生 (B3 派生出 B35) IM2001 foot/flat bottom flange mounted, from IM1001 (B35 flat bottom flange from B3).	M/P	M/P	M/P	M/P	M/P	M/P	M/P	M/P	-	-	-	-	-	-	
999D003	加强型铸件 Reinforced casting.	P	P	P	P	P	P	P	P	P	P	P	P	P	P	
喷漆 Painting																
114	特殊油漆颜色, 标准等级 (此代码需注明备注限定颜色种类的编号, 列表之外的其它颜色需同时选用 999/ 限定范围之外的特殊油漆颜色, 标准等级) Special paint color, standard grade.	M/P	M/P	M/P	M/P	M/P	M/P	M/P	M/P	M/P	M/P	M/P	M/P	M/P	M/P	
999E001	限定范围之外的特殊油漆颜色, 标准等级 (必须与 VC114 同用, 适用于 VC114 适用颜色列表之外, 此代码每单最低收费 2510 元) Special paint color (excluding 8 colors in list), apply together with code 114.	M/P	M/P	M/P	M/P	M/P	M/P	M/P	M/P	M/P	M/P	M/P	M/P	M/P	M/P	
115	C4M 喷漆系统, 根据 ISO 12944-5:2007 Painting system C4M acc. to ISO 12944-2: 1998.	P	P	P	P	P	P	P	P	P	P	P	P	P	P	
754	C5M 喷漆系统, 根据 ISO 12944-5:2007 Painting system C5M acc. to ISO 12944-2:1998.	P	P	P	P	P	P	P	P	P	P	P	P	P	P	
防护 Protection																
005	金属防护罩, 立式电机, 轴伸向下 Protective roof, vertical motor, shaft down.	M/P	M/P	M/P	M/P	M/P	M/P	M/P	M/P	M/P	M/P	M/P	M/P	M/P	M/P	
072	D 端径向密封 (不适用于 280,315 的 2 极电机) Radial seal at D-end. Not possible for 2-pole, 280 and 315 frames	M/P	M/P	M/P	M/P	M/P	M/P	M/P	M/P	M/P	M/P	M/P	M/P	M/P	-	
158	防护等级 IP65 Degree of protection IP65.	M/P	M/P	M/P	M/P	M/P	M/P	M/P	M/P	M/P	M/P	M/P	M/P	M/P	M/P	
403	防护等级 IP56 Degree of protection IP56.	M/P	M/P	M/P	M/P	M/P	M/P	M/P	M/P	M/P	M/P	M/P	M/P	M/P	M/P	
784	D 端伽玛密封 Gamma-seal at D-end.	M/P	M/P	M/P	M/P	M/P	M/P	M/P	M/P	M/P	M/P	M/P	M/P	M/P	M/P	
铭牌和指示牌 Rating & instruction plates																
002	重敲铭牌电压、频率、输出、连续工作制 Restamping voltage, frequency and output, continuous duty.	M/P	M/P	M/P	M/P	M/P	M/P	M/P	M/P	M/P	M/P	M/P	M/P	M/P	M/P	
095	重敲输出 (持续电压、频率)、间歇工作制 Restamping output (maintained voltage, frequency), intermittent duty.	M/P	M/P	M/P	M/P	M/P	M/P	M/P	M/P	M/P	M/P	M/P	M/P	M/P	M/P	
135	安装额外不锈钢指示牌 Mounting of additional identification plate, stainless.	M/P	M/P	M/P	M/P	M/P	M/P	M/P	M/P	M/P	M/P	M/P	M/P	M/P	M/P	

¹⁾ 特定变量代码不能同时使用。

¹⁾ Certain variant codes cannot be used simultaneously.

代码 ¹⁾	变量代码	M2BAX													
Code ¹⁾	Variant code	71	80	90	100	112	132	160	180	200	225	250	280	315	355
159	额外带铭牌 "Made in ..." Additional plate with text "Made in ..."	M/P	M/P	M/P	M/P	M/P	M/P	M/P	M/P	M/P	M/P	M/P	M/P	M/P	M/P
163	变频铭牌, 数据根据报价单 Frequency converter rating plate. Rating data according to quotation.	P	P	P	P	P	P	P	P	P	P	P	P	P	P
轴和转子 Shaft & rotor															
069	标准双出轴 Two shaft extensions according to catalog drawings.	P	P	P	P	P	P	P	P	P	P	P	P	P	P
070	D 端特殊轴伸, 标准材料 (需先技术确认) Special shaft extension at D-End, standard shaft material.	P	P	P	P	P	P	P	P	P	P	P	P	P	P
164	闭口键槽轴伸 Shaft extension with closed keyway.	P	P	P	P	P	P	P	P	P	P	P	P	P	P
标准和规范 Standards and regulations															
540	中国能效标签 China energy label	S	S	S	S	S	S	S	S	S	S	S	S	S	S
定子绕组温度传感器 Stator winding temperature sensors															
121	定子绕组双金属检测器, 制动型 (NCC), (3 个串联), 130°C Bimetal detectors, break type (NCC), (3 in series), 130 °C, in stator winding.	M/P	M/P	M/P	M/P	M/P	M/P	M/P	M/P	M/P	M/P	M/P	M/P	M/P	M/P
122	定子绕组双金属检测器, 制动型 (NCC), (3 个串联), 150°C Bimetal detectors, break type (NCC), (3 in series), 150 °C, in stator winding.	M/P	M/P	M/P	M/P	M/P	M/P	M/P	M/P	M/P	M/P	M/P	M/P	M/P	M/P
435	定子绕组安装 PTC 热敏电阻 (3 个串联), 130°C PTC - thermistors (3 in series), 130 °C, in stator winding.	M/P	M/P	M/P	M/P	M/P	M/P	M/P	M/P	M/P	M/P	M/P	M/P	M/P	M/P
436	定子绕组安装 PTC 热敏电阻 (3 个串联), 150°C PTC - thermistors (3 in series), 150 °C, in stator winding.	M/P	M/P	M/P	M/P	M/P	M/P	M/P	M/P	M/P	M/P	M/P	S	S	S
439	定子绕组安装 PTC 热敏电阻 (2x3 个串联), 150°C PTC - thermistors (2x3 in series), 150 °C, in stator winding.	R	R	R	R	R	R	P	P	P	P	P	P	P	P
441	定子绕组安装 PTC 热敏电阻 (3 个串联, 130°C 和 3 个串联, 150°C) PTC - thermistors (3 in series, 130 °C & 3 in series, 150 °C), in stator winding.	P	P	P	P	P	P	P	P	P	P	P	M/P	M/P	M/P
445	定子绕组安装 Pt100 (2 线), 每相 1 个 Pt100 2-wire in stator winding, 1 per phase.	P	P	P	P	P	P	P	P	P	P	P	M/P	M/P	M/P
接线盒 Terminal box															
020	可拆卸接线盒 Detached terminal box.	P	P	P	P	P	P	P	P	P	P	P	P	P	P
021	左侧接线盒 (从 D 端看) Terminal box LHS (seen from D-end).	-	P	P	P	P	P	P	P	P	P	P	R	R	R
022	左端电缆入口 (从 D 端看) Cable entry LHS (seen from D-end).	P	P	P	P	P	P	M/P	M/P	M/P	M/P	M/P	M/P	M/P	M/P
180	右侧接线盒 (从 D 端看) Terminal box RHS (seen from D-end).	-	P	P	P	P	P	P	P	P	P	P	R	R	R
230	标准金属电缆密封管 Standard metal cable gland.	M/P	M/P	M/P	M/P	M/P	M/P	M/P	M/P	M/P	M/P	M/P	M/P	M/P	M/P
375	标准塑料电缆密封管 Standard plastic cable gland.	M/P	M/P	M/P	M/P	M/P	M/P	M/P	M/P	M/P	M/P	M/P	M/P	M/P	M/P
376	两个标准塑料电缆密封管 Two standard plastic cable glands.	M/P	M/P	M/P	M/P	M/P	M/P	M/P	M/P	M/P	M/P	M/P	M/P	M/P	M/P
400	4 x 90 度可转动的接线盒 4 x 90 degr turnable terminal box.	M/P	M/P	M/P	M/P	M/P	M/P	S	S	S	S	S	S	S	S
413	延长电缆连接, 无接线盒 Extended cable connection, no terminal box.	P	P	P	P	P	P	P	P	P	P	P	P	P	P

¹⁾ 特定变量代码不能同时使用。

¹⁾ Certain variant codes cannot be used simultaneously.

代码 ¹⁾ Code ¹⁾	变量代码 Variant code	M2BAX														
		71	80	90	100	112	132	160	180	200	225	250	280	315	355	
418	辅件用独立接线盒, 标准材料 Separate terminal box for auxiliaries, standard material.	P	P	P	P	P	P	P	P	P	P	P	R	R	R	
447	用于监测装置的独立接线盒, 顶部安装 Top mounted separate terminal box for monitoring equipment.	-	-	-	-	-	-	-	-	-	-	-	M/P	M/P	M/P	
468	电缆从 D 端进口 Cable entry from D-end.	M/P	M/P	M/P	M/P	M/P	M/P	M/P	M/P	M/P	M/P	M/P	M/P	M/P	M/P	
469	电缆从 N 端进口 Cable entry from N-end.	M/P	M/P	M/P	M/P	M/P	M/P	M/P	M/P	M/P	M/P	M/P	M/P	M/P	M/P	
731	两个标准金属电缆密封管 Two standard metal cable glands.	M/P	M/P	M/P	M/P	M/P	M/P	M/P	M/P	M/P	M/P	M/P	M/P	M/P	M/P	
753	铸铁接线盒 Cast iron terminal box.	P	P	P	P	P	P	P	P	P	P	P	S	S	S	
999K009	预留非标出线孔 Non-standard cable entry.	P	P	P	P	P	P	P	P	P	P	P	P	P	P	
测试 Testing																
145	样本电机的型式试验报告, 400V 50Hz Type test report from a catalogue motor, 400V 50Hz.	M/P	M/P	M/P	M/P	M/P	M/P	M/P	M/P	M/P	M/P	M/P	M/P	M/P	M/P	
146	指定交货批次中的一台电机, 进行型式试验并附带试验报告 Type test with report for one motor from specific delivery batch.	M/P	M/P	M/P	M/P	M/P	M/P	M/P	M/P	M/P	M/P	M/P	M/P	M/P	M/P	
148	出厂试验报告 Routine test report.	M/P	M/P	M/P	M/P	M/P	M/P	M/P	M/P	M/P	M/P	M/P	M/P	M/P	M/P	
变速驱动器 Variable speed drives																
701	N 端绝缘轴承 Insulated bearing at N-end.	-	-	-	-	-	-	-	-	-	-	-	-	P	P	P
704	EMC 电缆密封管 EMC cable entry.	R	R	R	R	R	R	R	R	R	R	R	R	M/P	M/P	M/P

¹⁾ 特定变量代码不能同时使用。

¹⁾ Certain variant codes cannot be used simultaneously.

特定变量代码不能同时使用,
详情请咨询 ABB。

S = 标准电机包含

M = 可选, 库存电机改装

P = 可选, 新生产电机

R = R

- = 不适用

Certain variant codes cannot be used simultaneously.
Contact ABB for more details.

S = Included as standard

M = Available as option, modification from stock

P = Available as option, new manufacture only

R = On request

- = Not applicable

一般用途电机简介

General performance motors in brief

机座号 71-132
Frame size 71-132

电机尺寸 Motor size		71	80	90	100	112	132
机座与端盖 Stator and end shields	材料 Material	铸铁 Cast iron					
	油漆颜色 Paint color shade	Munsell 蓝 8B 4.5/3.25 Munsell blue 8B 4.5/3.25					
	防腐蚀等级 Corrosion class	C3 (中等) C3 (medium)					
底脚 Feet		一体式铸铁底脚 Integrated cast iron feet					
轴承 Bearings	D 端 D-end	6203-2Z/C3	6204-2Z/C3	6205-2Z/C3	6206-2Z/C3	6206-2Z/C3	6208-2Z/C3
	N 端 N-end	6202-2Z/C3	6203-2Z/C3	6204-2Z/C3	6205-2Z/C3	6205-2Z/C3	6208-2Z/C3
轴向锁定轴承 Axially locked bearings		D 端锁定 Locked at D-end					
轴承密封 Bearing seals	D 端, N 端 D-end, N-end	V 形圈 V-ring					
润滑 Lubrication		永久润滑封闭轴承 Permanently lubricated shielded bearings					
铭牌 Rating plate	材料 Material	不锈钢 Stainless steel					
接线盒 Terminal box	接线盒材料 Frame material	铸铁 Cast iron					
	接线盒盖材料 Cover material	钢板 Steel					
	防腐蚀等级 Corrosion class	C3 (中等) C3 (medium)					
	螺钉 Screws	电镀锌钢 Zinc-electroplated steel					
连接件 Connections	螺纹孔 Threaded openings	2xM16	2xM25		2xM32		
	最大铜线 (Cu) 截面积 (mm ²) Max Cu-area mm ²	4	6		10		
	接线 Terminals	电缆接线头, 6 个端子 Cable lugs, 6 terminals					
风扇 Fan	材料 Material	玻璃纤维增强聚丙烯 Glass-fiber reinforced polypropylene					
风罩 Fan cover	材料 Material	钢板 Steel					
	油漆颜色 Paint color shade	Munsell 蓝 8B 4.5/3.25 Munsell blue 8B 4.5/3.25					
	防腐蚀等级 Corrosion class	C3 (中等) C3 (medium)					
定子绕组 Stator winding	材料 Material	铜 Copper					
	绝缘 Insulation	F 级绝缘, B 级温升, 除非另有规定 Insulation class F. Temperature rise class B unless otherwise stated					
	绕组保护 Winding protection	可选 As option					
转子绕组 Rotor winding	材料 Material	压铸铝 Pressure die-cast aluminum					
平衡方法 Balancing method		半键平衡 Half-key balancing as standard					
排水孔 Drain holes		排水孔具有可闭堵塞, 交付时为打开状态 Drain holes with closable plastic plugs, open on delivery					
键槽 Keyway		开口槽 Open keyway					
防护等级 Enclosure		IP 55					
冷却方式 Cooling method		IC 411					
吊环 Lifting lug		一体式铸铁吊环 Integrated cast iron lifting lug					

一般用途电机简介

General performance motors in brief

机座号 160-250
Frame size 160-250

电机尺寸 Motor size		160	180	200	225	250
机座与端盖 Stator and end shields	材料 Material	铸铁 Cast iron				
	油漆颜色 Paint color shade	Munsell 蓝 8B 4.5/3.25 Munsell blue 8B 4.5/3.25				
	防腐蚀等级 Corrosion class	C3 (中等) C3 (medium)				
底脚 Feet		一体式铸铁底脚 Integrated cast iron feet				
轴承 Bearings	D 端 D-end	6209-2Z/C3	6210-2Z/C3	6212-2Z/C3	6213-2Z/C3	6215-2Z/C3
	N 端 N-end	6209-2Z/C3	6209-2Z/C3	6209-2Z/C3	6210-2Z/C3	6212-2Z/C3
轴向锁定轴承 Axially locked bearings		D 端锁定 Locked at D-end				
轴承密封 Bearing seals	D 端, N 端 D-end, N-end	V 形圈 V-ring				
润滑 Lubrication		永久润滑封闭轴承 Permanently lubricated shielded bearings				
铭牌 Rating plate	材料 Material	不锈钢 Stainless steel				
接线盒 Terminal box	接线盒材料 Frame material	铸铁 Cast iron				
	接线盒盖材料 Cover material	钢板 Steel				
	防腐蚀等级 Corrosion class	C3 (中等) C3 (medium)				
	螺钉 Screws	电镀锌钢 Zinc-electroplated steel				
连接件 Connections	螺纹孔 Threaded openings	2xM40+M16			2xM63+M16	
	最大铜线 (Cu) 截面积 (mm ²) Max Cu-area mm ²	35			70	
	接线 Terminals	电缆接线头, 6 个端子 Cable lugs, 6 terminals				
风扇 Fan	材料 Material	玻璃纤维增强聚丙烯 Glass-fiber reinforced polypropylene				
风罩 Fan cover	材料 Material	钢板 Steel				
	油漆颜色 Paint color shade	Munsell 蓝 8B 4.5/3.25 Munsell blue 8B 4.5/3.25				
	防腐蚀等级 Corrosion class	C3 (中等) C3 (medium)				
定子绕组 Stator winding	材料 Material	铜 Copper				
	绝缘 Insulation	F 级绝缘, B 级温升, 除非另有规定 Insulation class F. Temperature rise class B unless otherwise stated				
	绕组保护 Winding protection	可选 As option				
转子绕组 Rotor winding	材料 Material	压铸铝 Pressure die-cast aluminum				
平衡方法 Balancing method		半键平衡 Half-key balancing as standard				
排水孔 Drain holes		排水孔具有可闭合塞, 交付时为打开状态 Drain holes with closable plastic plugs, open on delivery				
键槽 Keyway		开口槽 Open keyway				
防护等级 Enclosure		IP 55				
冷却方式 Cooling method		IC 411				
吊环 Lifting lug		一体式铸铁吊环 Integrated cast iron lifting lug				

一般用途电机简介

General performance motors in brief

机座号 280-355
Frame size 280-355

电机尺寸 Motor size		280	315	355
机座与端盖 Stator and end shields	材料 Material	铸铁 Cast iron		
	油漆颜色 Paint color shade	Munsell 蓝 8B 4.5/3.25 Munsell blue 8B 4.5/3.25		
	防腐蚀等级 Corrosion class	C3 (中等) C3 (medium)		
底脚 Feet		一体式铸铁底脚 Integrated cast iron feet		
轴承 Bearings	D 端 D-end	6217/C3	6217/C3 (2P) 6219/C3 (4-6P)	6219/C3 (2P) 6222/C3 (4-6P)
	N 端 N-end	6316/C3 (IE2) 6217/C3 (IE3)	6217/C3	6219/C3
轴向锁定轴承 Axially locked bearings		D 端锁定 Locked at D-end		
轴承密封 Bearing seals	D 端, N 端 D-end, N-end	V 形圈 V-ring		
润滑 Lubrication		可润滑轴承 Regreasable bearings		
铭牌 Rating plate	材料 Material	不锈钢 Stainless steel		
接线盒 Terminal box	接线盒材料 Frame material	铸铁 Cast iron		
	接线盒盖材料 Cover material	铸铁 Cast iron		
	防腐蚀等级 Corrosion class	C3 (中等) C3 (medium)		
	螺钉 Screws	电镀锌钢 Zinc-electroplated steel		
连接件 Connections	螺纹孔 Threaded openings	2xM63+2xM20	2xM63+2xM20	2xM75+2xM20
	最大铜线 (Cu) 截面积 (mm ²) Max Cu-area mm ²	2x150	2x240	4x240
	接线 Terminals	电缆接线头, 6 个端子 Cable lugs, 6 terminals		
风扇 Fan	材料 Material	玻璃纤维增强聚丙烯 Glass-fiber reinforced polypropylene		
风罩 Fan cover	材料 Material	钢板 Steel		
	油漆颜色 Paint color shade	Munsell 蓝 8B 4.5/3.25 Munsell blue 8B 4.5/3.25		
	防腐蚀等级 Corrosion class	C3 (中等) C3 (medium)		
定子绕组 Stator winding	材料 Material	铜 Copper		
	绝缘 Insulation	F 级绝缘, B 级温升, 除非另有规定 Insulation class F. Temperature rise class B unless otherwise stated		
	绕组保护 Winding protection	定子绕组安装 PTC 热敏电阻 (3 个串联), 150°C PTC - thermistors (3 in series), 150 °C, in stator winding.		
转子绕组 Rotor winding	材料 Material	压铸铝 Pressure die-cast aluminum		
平衡方法 Balancing method		半键平衡 Half-key balancing as standard		
排水孔 Drain holes		排水孔具有可闭合塞, 交付时为打开状态 Drain holes with closable plastic plugs, open on delivery		
键槽 Keyway		开口槽 Open keyway		
防护等级 Enclosure		IP 55		
冷却方式 Cooling method		IC 411		
吊环 Lifting lug		分体式钢制吊环, 通过吊环螺栓连接到机座 Separate steel lifting lug, bolted to the stator		

联系我们

Contact us

ABB 中国电机与发电机业务单元区域中心

北方区域中心（北京、天津、河北、河南、山西及内蒙古）

北京市朝阳区酒仙桥路 10 号恒通广厦
邮编：100015
电话：010-8456 6688
传真：010-6423 1613

南方区域中心（广东、广西、福建及海南）

广东省广州市珠江新城珠江西路 15 号珠江城大厦 29 楼
邮编：510623
电话：020-3785 0613
传真：020-3785 0608

东区 - 上海区域中心（上海和浙江）

上海市闵行区天星路 380 号
邮编：200245
电话：021-6113 7688
传真：021-6113 7788

东区 - 南京区域中心（江苏、安徽及山东）

南京市洪武北路 55 号置地广场 11 楼
邮编：210005
电话：025-8476 5716
传真：025-8663 5338

西北区域中心（陕西、宁夏、新疆、青海及甘肃）

西安市经济技术开发区文景路中段 158 号
邮编：710075
电话：029-8575 8288
传真：029-8575 8299

西南区域中心（四川、云南、贵州、西藏及重庆）

成都市人民南路四段 3 号来福士广场 T1 栋 8 楼
邮编：610042
电话：028-8526 8800
传真：028-8526 8900

华中区域中心（湖北、湖南及江西）

湖北省武汉市武昌区临江大道 96 号武汉万达中心 21 楼
邮编：430060
电话：027-8839 5888
传真：027-8839 5999

东北区域中心（辽宁、吉林及黑龙江）

辽宁省沈阳市和平区南京北街 206 号沈阳假日城市广场 2 座 16 楼
邮编：110001
电话：024-3132 7741
传真：024-3132 6699

我们有权进行技术修改或更改本文件内容，恕不另行通知。采购订单适用协议细节。对本文件可能存在的失误或信息不足，ABB 不承担任何责任。

我们保留对本文件、主题及其中插图的所有权。禁止在未事先获得 ABB 书面同意的情况下向第三方复印、公布或私自使用本文件内容（无论是全部内容还是部分内容）。

@ Copyright 2016 ABB.

版权所有。

All rights reserved



扫码登陆 ABB 官网电机与发电机产品页面，通过在页面下方提交您对产品和服务的问题，同时预留您的联系方式，ABB 相关销售人员将在第一时间与您取得联系，给您专业、及时的回复。